



Standard 4th axis



Mini 4th axis

Rotary 4th Axis Owners Manual

To Our Customers

Thank you for purchasing the Rotary 4th Axis accessory. Your Rotary 4th Axis brings the speed and precision of Rotary CNC to your shop and greatly expands the capabilities of your CNC machine.

This manual provides setup, operational information for your Rotary 4th Axis. Please read the manual carefully. This manual also includes our warranty (page 7) and important safety information (page 5).

This manual has been written with the assumption that the owner is familiar with the basic operation of a computer as well as the required technical knowledge required for the safe operation of woodworking power tools. Information in this manual is subject to change without notice.

This manual is also written under the assumption the owner has spent time learning how use Vectric the VCarve or Aspire software that is used to create the toolpath files used by your CNC machine and Rotary 4th axis. Again, thank you for purchasing the Rotary 4th Axis. We are confident you will be pleased with its performance and ability to create a wide variety of projects and materials.

If you have **questions or comments**, please contact us at : Next Wave CNC, LLC, 600 W. Boundary St., Perrysburg, Ohio 43551 USA, Phone – (419) 318-4822, or email us at: info@NextWaveCNC.com

For **Technical Support** please: email us at: support@NextWaveCNC.com, or visit our Support page at: www.NextWaveCNC.com/support For the fastest service please include your product model number, date of purchase, and any pertinent information that may be helpful such as .tap files, VCarve files, screen captures, and photos of your setup or problem.

Visit us on the web at: NextWaveCNC.com

Owner manual updates

This manual will be periodically updated. For the most recent version visit:
www.NextWaveCNC.com/downloads-links

Controller, Pendant and Firmware updates

For the most recent version visit: www.NextWaveCNC.com/downloads-links

Copyright Next Wave CNC All Rights Reserved. **Information in this manual is subject to change without notice.** Software copyright by Next Wave CNC. All rights reserved. All other trademarks are the property of their respective owners.

Table of Contents

	Page
To Our Customers	2
Warranty	4
Technical Support	4
Safety	5
Firmware updates	6
Adding 4th Axis Post Processors to VCarve or Aspire	7
<u>Standard 4th Axis (Shark only)</u>	
Parts overview	10
First time setup	
4th Axis Driver Card installation	11
4th Axis cable hookup	14
Pendant setup	15
Four-jaw chuck installation	18
Gantry height adjustment.....	19
X and Y mounting options	20
Headstock and Tailstock alignment process	21
<u>Mini 4th Axis setup (Shark and Piranha)</u>	
Parts overview	28
First time setup	
Pendant setup	29
Control Box hookup	32
X and Y mounting options	33
Headstock and Tailstock alignment process	34
<u>Rotary 4th Axis Workflow (applies to both Standard and Mini)</u>	
Workflow Summary	41
Workflow Step-by-Step Practice Project	42
Design and Toolpath Phase Using VCarve Desktop	43
Design and Toolpath Phase Using VCarve Pro	54
4 th Axis Zeroing process	62
Running the 4 th axis toolpath	72
Maintenance	74
Web resources	74

Warranty

Next Wave CNC warrants to the original retail purchaser of a CNC Shark 4th Axis Accessory and purchased from an authorized CNC Shark distributor will be free from defects in material and workmanship for ONE YEAR from the date of purchase. This warranty is for parts and labor to correct the defect, and does not cover the cost of shipping the defective item(s) to Next Wave CNC for repair.

This warranty does not apply to defects arising from normal wear and tear, misuse, abuse, negligence, accidents, unauthorized repair or alteration, or lack of maintenance. This warranty is void if the CNC Shark 4th Axis Accessory or any portion of the CNC Shark 4th Axis Accessory is modified without the prior written permission of Next Wave CNC or if the CNC Shark 4th Axis Accessory is located or has been used outside the country of residence of the authorized CNC Shark distributor.

Please contact Next Wave CNC to take advantage of this warranty. If Next Wave CNC determines the CNC Shark 4th Axis Accessory is defective in material or workmanship, and not due to normal wear and tear, misuse, abuse, negligence, accidents, unauthorized repair or alteration, or lack of maintenance, then Next Wave CNC will, at its expense and upon proof of purchase, send replacement parts to the original retail purchaser necessary to cure the defect. Next Wave CNC will repair the CNC Shark 4th Axis Accessory provided the necessary components are returned to Next Wave CNC, shipping prepaid, with proof of purchase and within the warranty period.

Next Wave CNC disclaims all other express or implied warranties, including fitness for a particular purpose. Next Wave CNC shall not be liable for death, injuries to persons or property, or incidental, consequential, contingent or special damages arising from the use of the CNC Shark machine.

TECHNICAL SUPPORT

Next Wave CNC is committed to helping you get your Rotary 4th axis up and running as quickly as possible. If you experience any difficulties please contact our technical support team:

On the web at: <https://www.NextWaveCNC.com/support>

By email at: support@NextWaveCNC.com

By phone at: (419)491-4520 during Mon-Fri 9AM-5PM Eastern time zone



1. Read safety and operating instructions before using the 4th Axis Rotary attachment
2. Take time to fully understand how to safely operate the 4th Axis Rotary attachment .
3. Position and attach the 4th Axis Rotary to your CNC per the instruction in this manual.
4. Always wear eye protection while operating your 4th Axis Rotary attachment .
5. **DO NOT** machine metal with your 4th Axis Rotary attachment
6. Never attempt to adjust the work piece or move the 4th Axis Rotary attachment while the it is running.
7. Use the Pause or Estop buttons to pause or stop the 4th Axis Rotary attachment in the middle of an operation.
8. Never leave the 4th Axis Rotary attachment unattended while it is running.
9. While operating the 4th Axis Rotary attachment , keep a multipurpose dry chemical fire extinguisher nearby. It must be rated for both A & C fires
10. For added safety and convenience, connect your CNC to a power strip with an on/off switch. This provides an additional way to turn off the machine in case of an emergency.
11. Follow all Safety instructions provide with your CNC machine and related accessories.
12. Follow accepted safety precautions and practices for woodworking and machining.

Firmware updates (All models)

If you have not recently updated the firmware for your LCD Pendant or Controller/ control box, now would be a good time to update both. The Standard and Mini rotary 4th axis attachments operate best with current firmware and may not function well with older firmware. Instructions on how to update your CNC control box and control pendant firmware can be downloaded from our website (see pictures below). Follow the instructions carefully and the updating process should only take about 10-15 minutes.

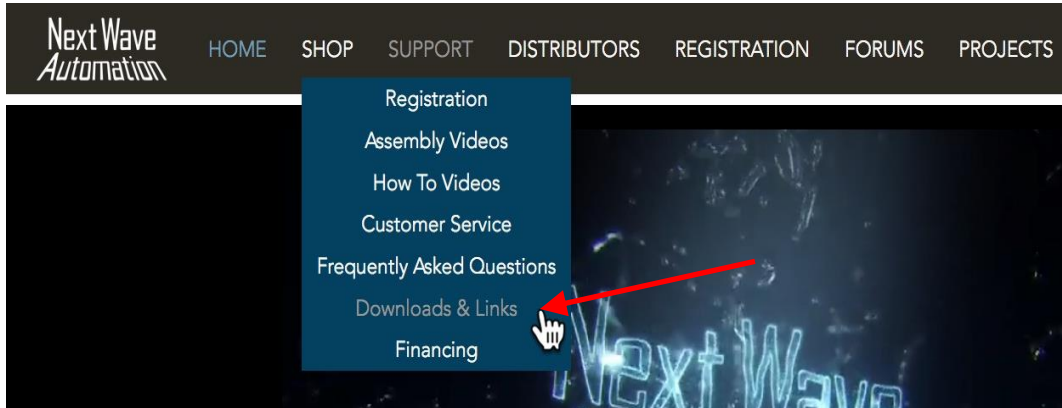

Go to <https://www.NextWaveCNC.com/downloads-links>

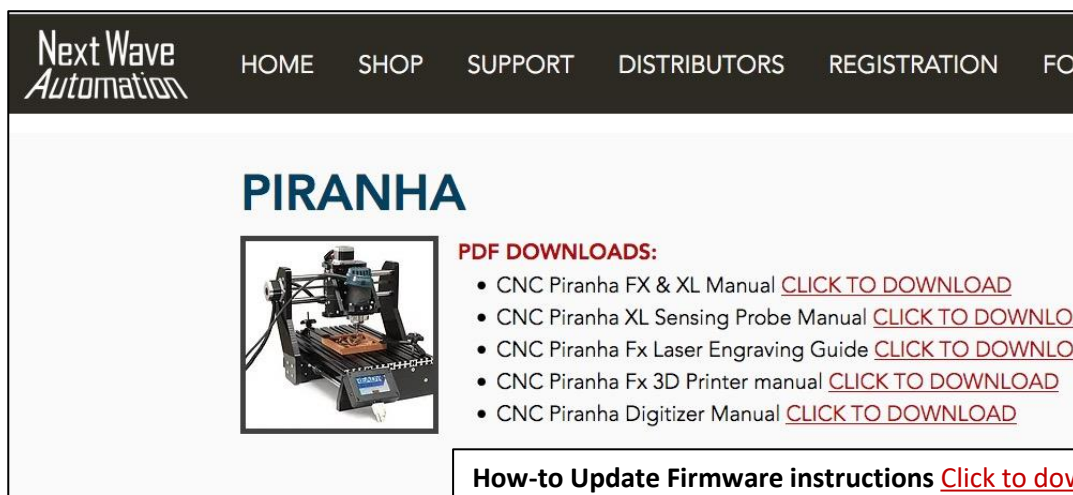
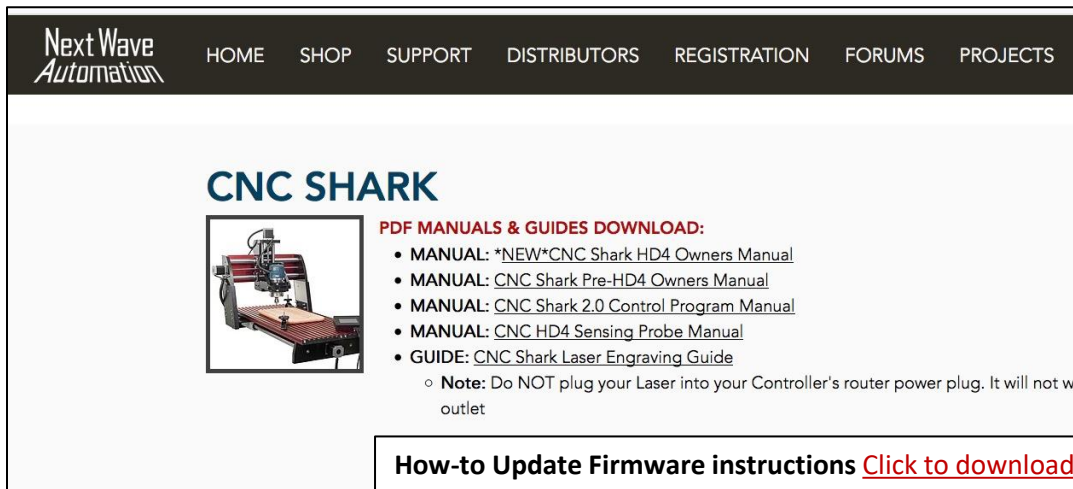

Adding a 4th Axis Post Processor to VCarve or Aspire

Post Processors are used to convert your designs and toolpaths into the g-code (.tap files) that you run on your CNC. The Rotary 4th axis requires specific post processors. Post Processors are periodically updated so now would be a good time to download and install the most recent versions. The following steps will guide you through the process of downloading and installing the CNC Shark Rotary post processors into VCarve or Aspire.

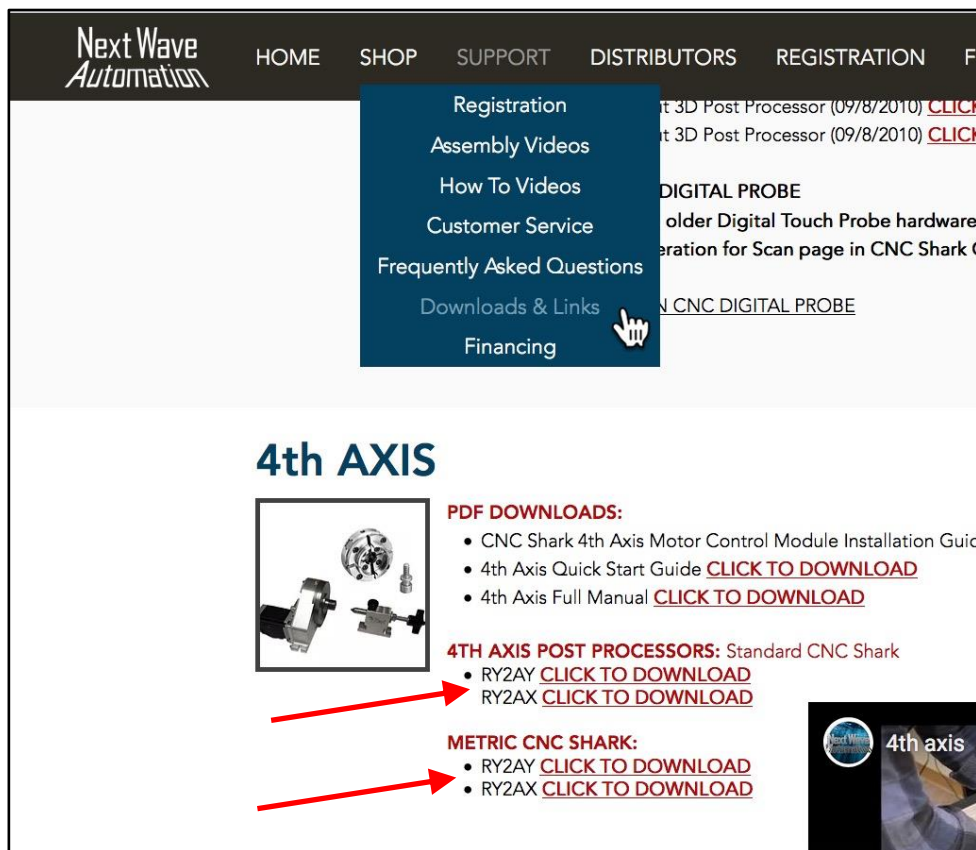

The screenshot shows the Next Wave Automation website. The navigation menu includes HOME, SHOP, SUPPORT, DISTRIBUTORS, REGISTRATION, and FINANCING. A dropdown menu is open under SUPPORT, listing options like Registration, Assembly Videos, How To Videos, Customer Service, Frequently Asked Questions, Downloads & Links, and Financing. The 'Downloads & Links' option is highlighted with a mouse cursor. Below the menu, the '4th AXIS' section is visible, featuring an image of a 4th axis motor control module. To the right of the image, there are three sections of download links: 'PDF DOWNLOADS' with links for the CNC Shark 4th Axis Motor Control Module Installation Guide, 4th Axis Quick Start Guide, and 4th Axis Full Manual; '4TH AXIS POST PROCESSORS: Standard CNC Shark' with links for RY2AY and RY2AX; and 'METRIC CNC SHARK' with links for RY2AY and RY2AX. Red arrows point from the text to the corresponding download links. A small image of a 4th axis accessory is also visible in the bottom right corner of the section.

Step 1 Go to <https://www.NextWaveCNC.com/downloads-links> and download the "inches" and/or the "metric" posts.

Save the files to a location on your computer that is easy to access, such as the Desktop.

NOTE: These post processors work with both the Standard and Mini 4th Axis accessories.

NOTE: Post Processors are periodically updated, so the names on the website may differ from the ones pictured above.

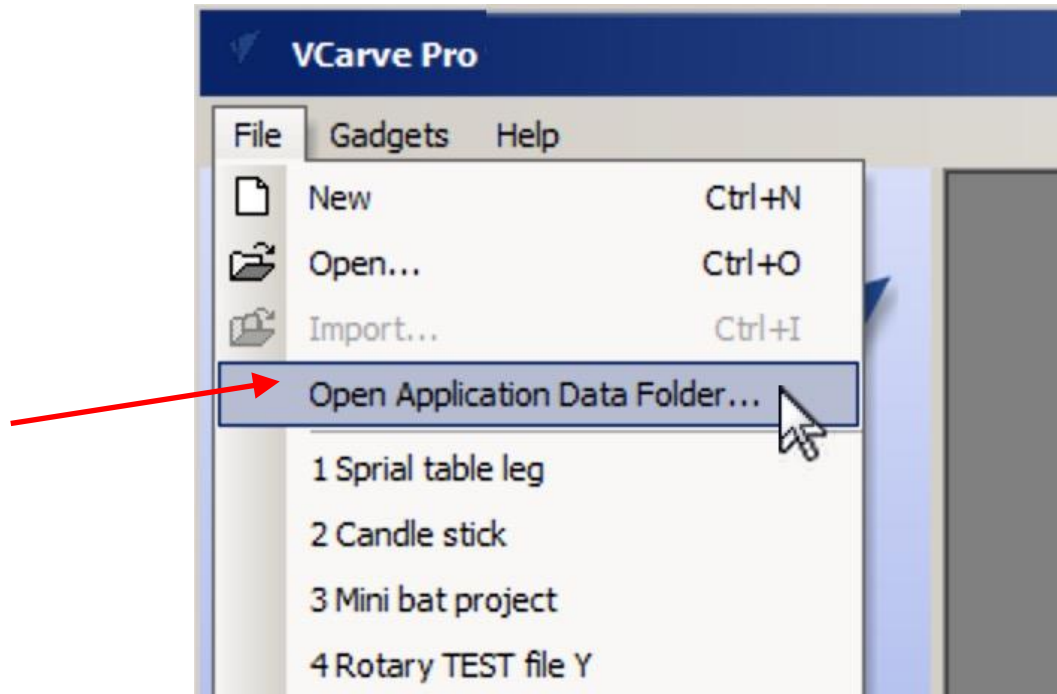

Step 2 Open your VCarve Pro or Aspire software. Go to "File" menu and select "Open Application Data Folder"

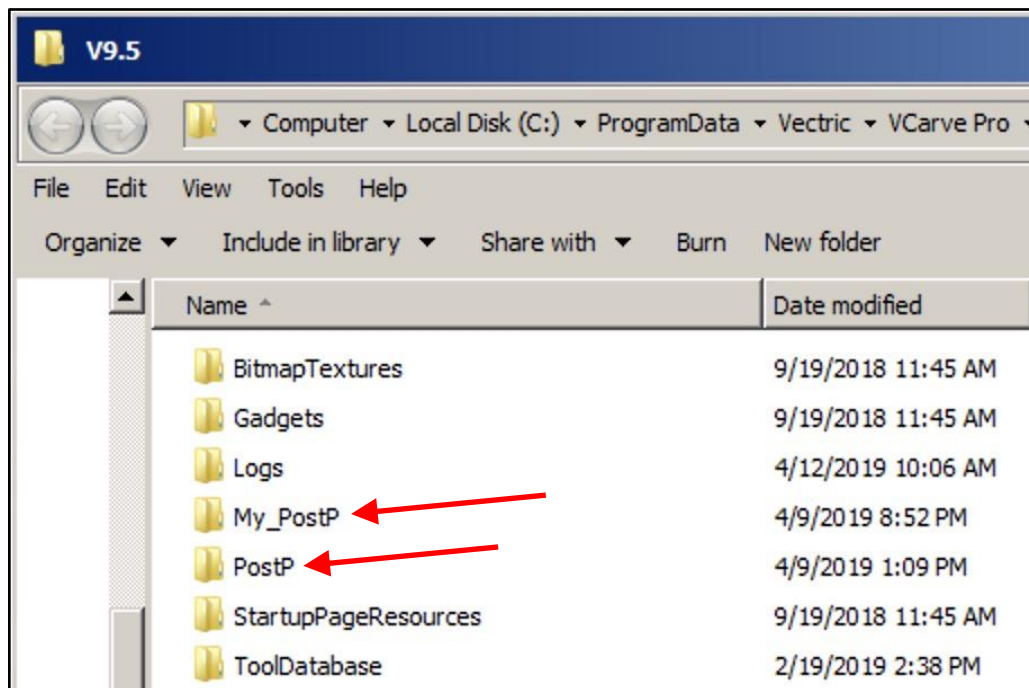

Step 3 Copy the Post Processor files from your computer and paste them into the **My_PostP** and **PostP** folders. If you have not used the **My_PostP** folder before, also copy your CNC Shark and/or Piranha posts from the **PostP** folder to the **My_PostP** folder. The advantage of using the **My_PostP** folder is that only those posts show up in the drop down window in VCarve or Aspire and hides the ones that are not needed. See picture on next page.

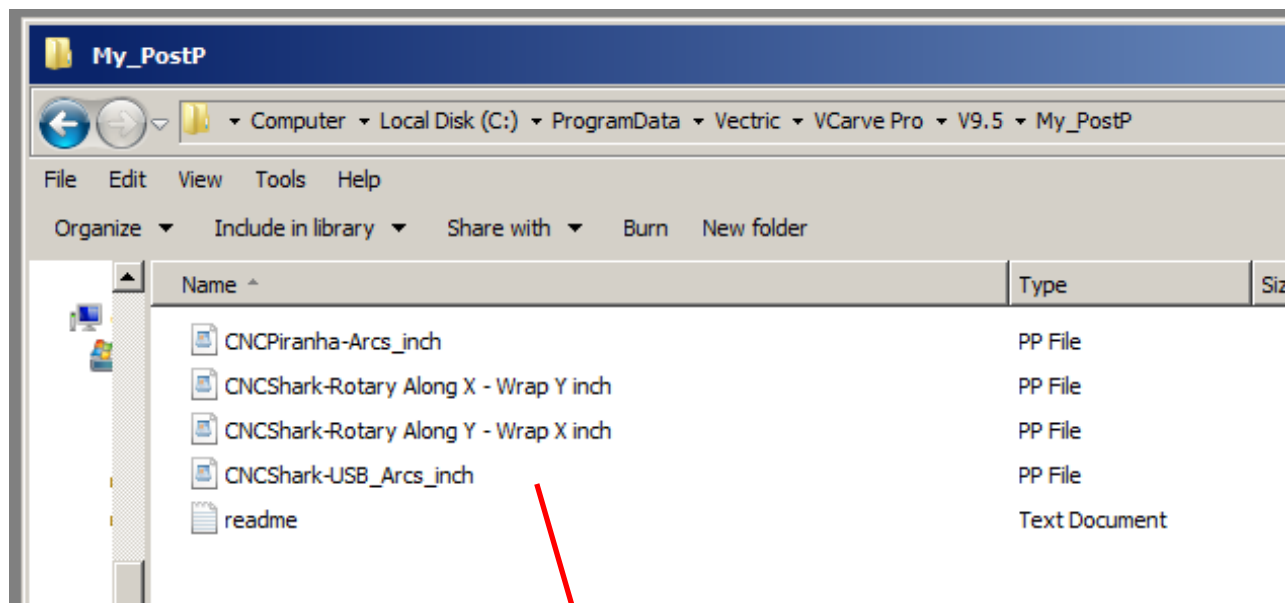

When you use the **My_PostP** folder, only these posts show up in the Post Processor drop down menu in the Save Toolpaths window.

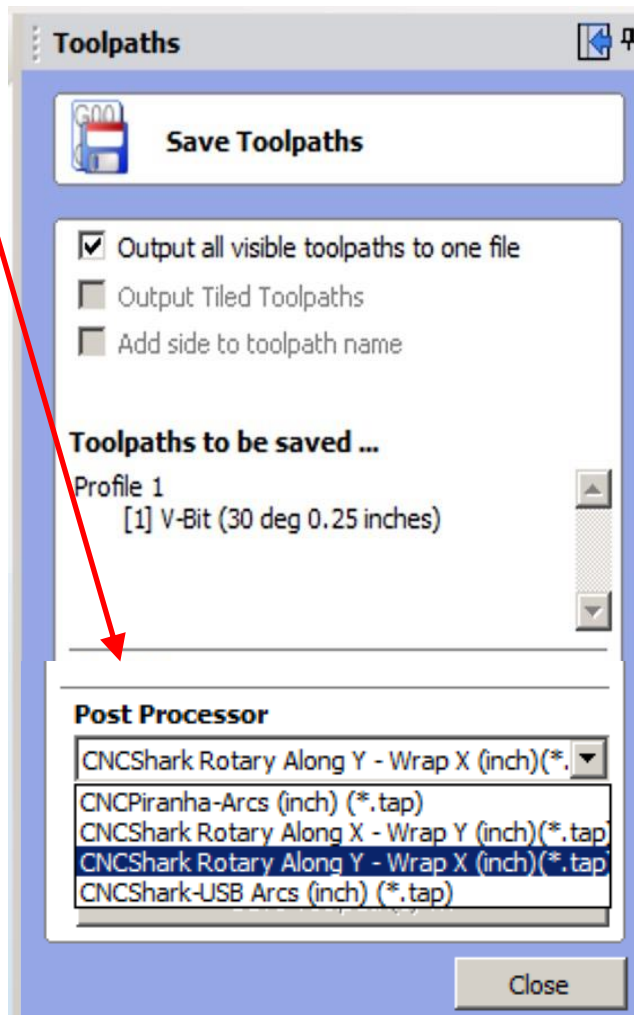

NOTE:
Post processor files are periodically updated and the file names shown here may differ from your software and current version on the website.

To download the most recent versions follow the instructions on page 7.

Standard 4th Axis Parts Overview

The Standard 4th Axis gives you the ability to create turned spindles, columns and "in-the round" 3D models. The Standard 4th Axis easily bolts to your existing CNCShark table. The headstock has a standard 1" x 8TPI drive shaft that allows you to attach a variety of lathe accessories.

The Standard 4th Axis comes with a precision 4 jaw chuck.

This manual assumes you currently own a CNCShark as well as Vectric VCarve or Aspire software and are familiar with how to use the software you own.



The CNCShark Rotary 4th Axis Accessory kit comes with the motorized headstock, 4-jaw chuck, adjustable tail stock and mounting hardware.



You will also need the 4th Axis driver board. Purchased separately at www.NewtWaveCNC.com.

Standard 4th Axis Driver Card installation

Before you can use your 4th axis, you will need to install the 4th axis driver card into the HD4 control box. Follow the steps and figures below to ensure that the driver card is installed properly.

IMPORTANT - Turn power **OFF** when connecting or disconnecting motor or accessory cables

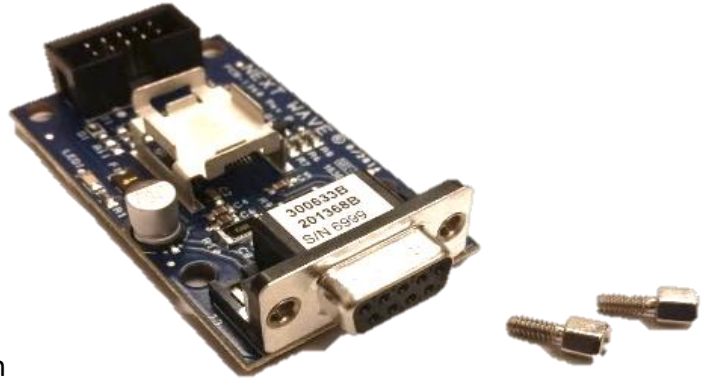

Step 1 Remove the 2 hex bolts with a 3/16th nut driver from the front of the driver board.

Step 2 Remove the sticker that reads, "OPTIONAL EXPANSION PORT" on the back of the control box. This will uncover a space for the 4th axis driver port.



Step 3 Use a Phillips screwdriver to remove the six screws (three on each side) from the control box so that the top cover can be removed.

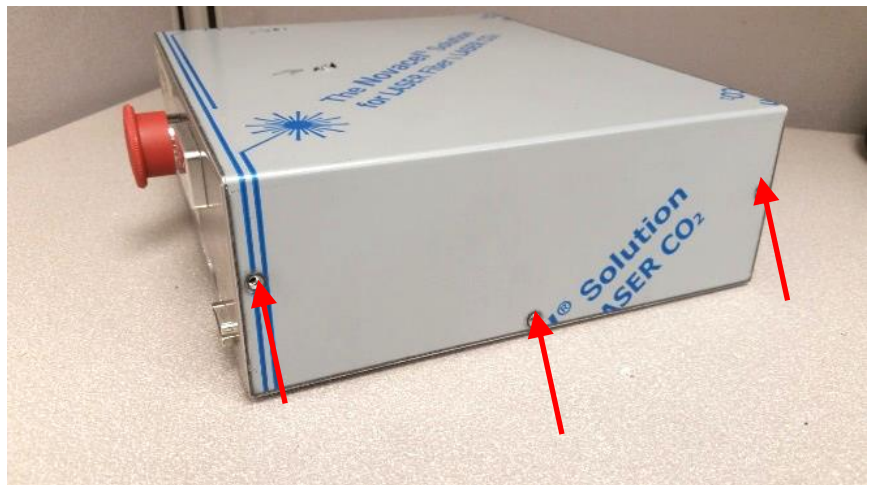

Step 4 Place the 4th axis driver board on the open aluminum heat sink, which is adjacent to the other three driver boards.

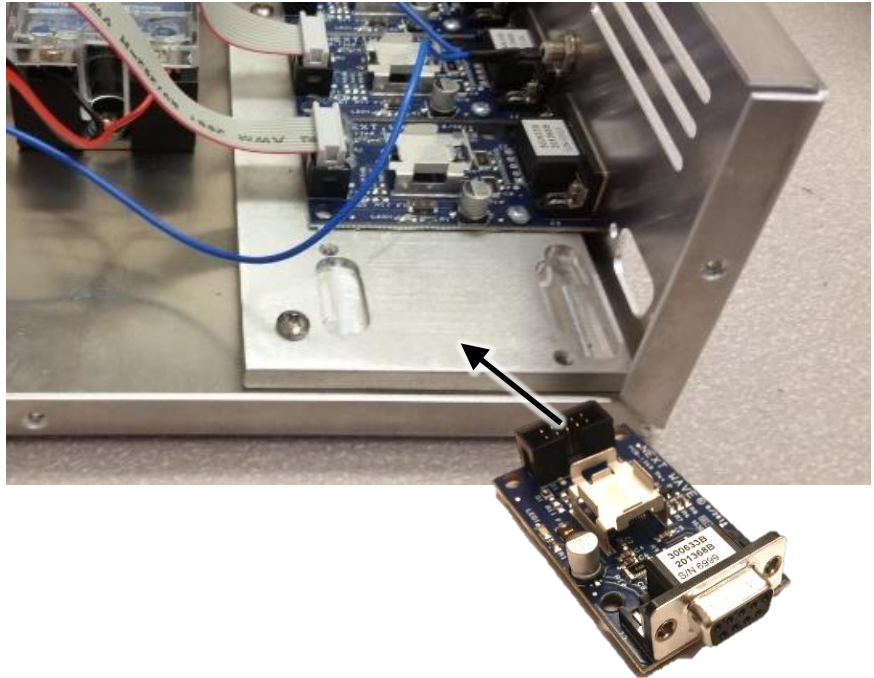

Step 5 Reattach the two hex bolts to the 4th axis driver board, securing it to the back of the control box. DO NOT fully tighten the 2 hex bolts at this time.



Step 6 Attach the 4th axis driver board to the aluminum heat sink with the two included screws. Once these screws are in place, fully tighten the screws and the two hex bolts attaching the 4th axis driver board to the back of the control box.

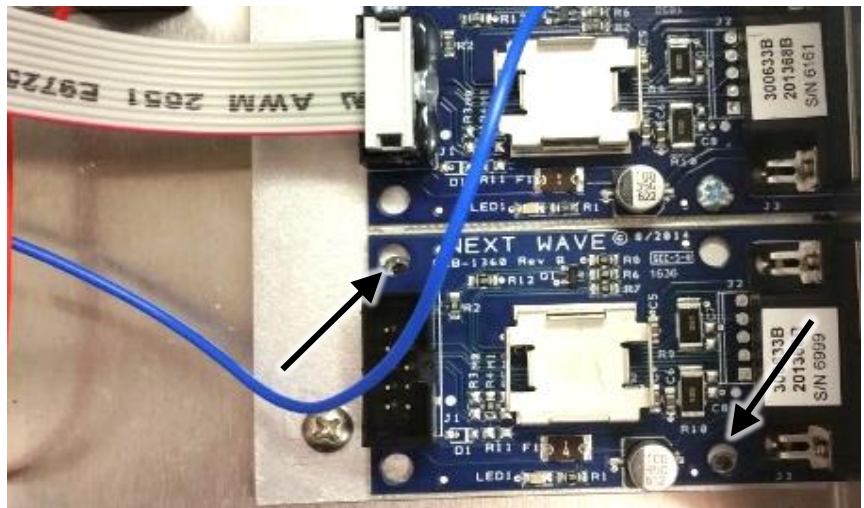

Standard 4th Axis Driver Card installation (cont.)

Step 7 Attach one end of the ribbon cable to the circuit board opposite the driver board. Push down gently on the end of the ribbon cable to affix it to the circuit board.

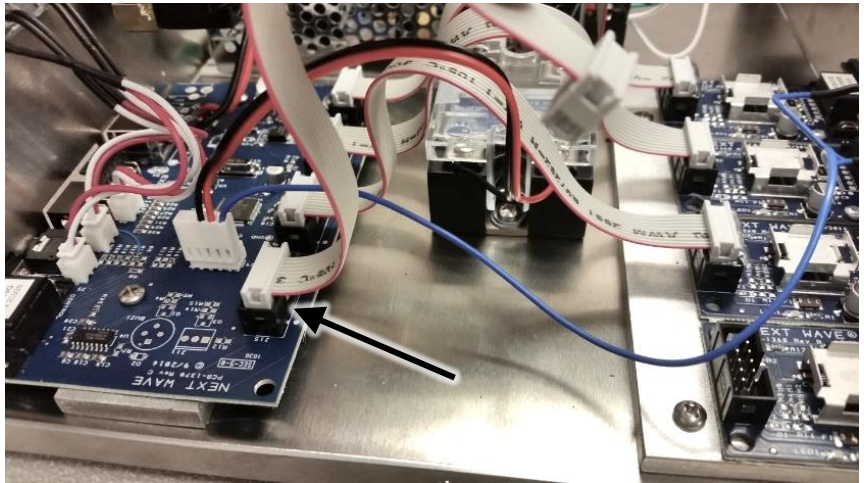

Step 8 Attach the remaining end of the ribbon cable to the driver board. (Optional: Secure the ribbon cable at both ends with a drop of hot glue to the outside of the connection.)

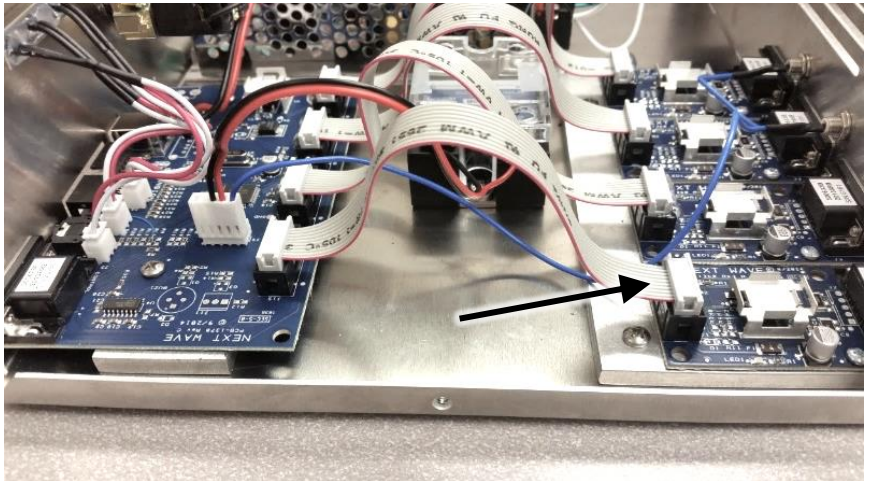

Step 9 Place the top cover back on the control box and reinstall the six screws.

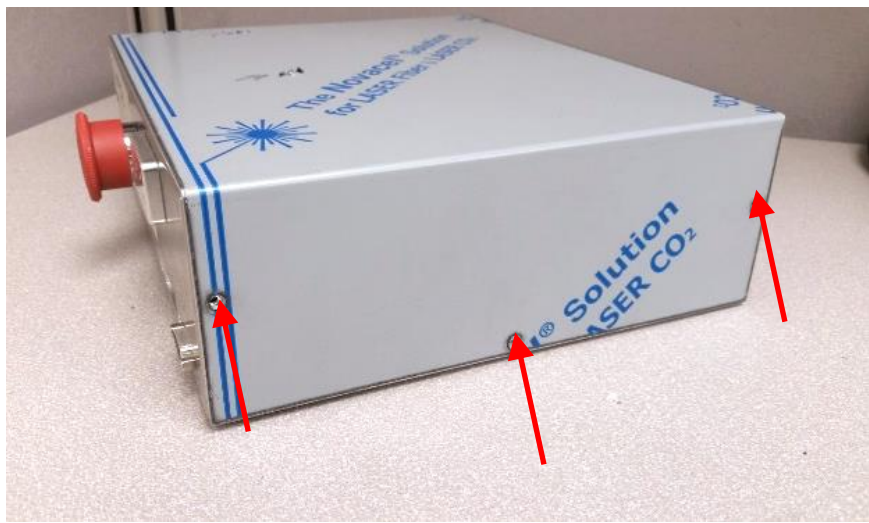



Step 10 Make sure power is turned OFF to the control box.

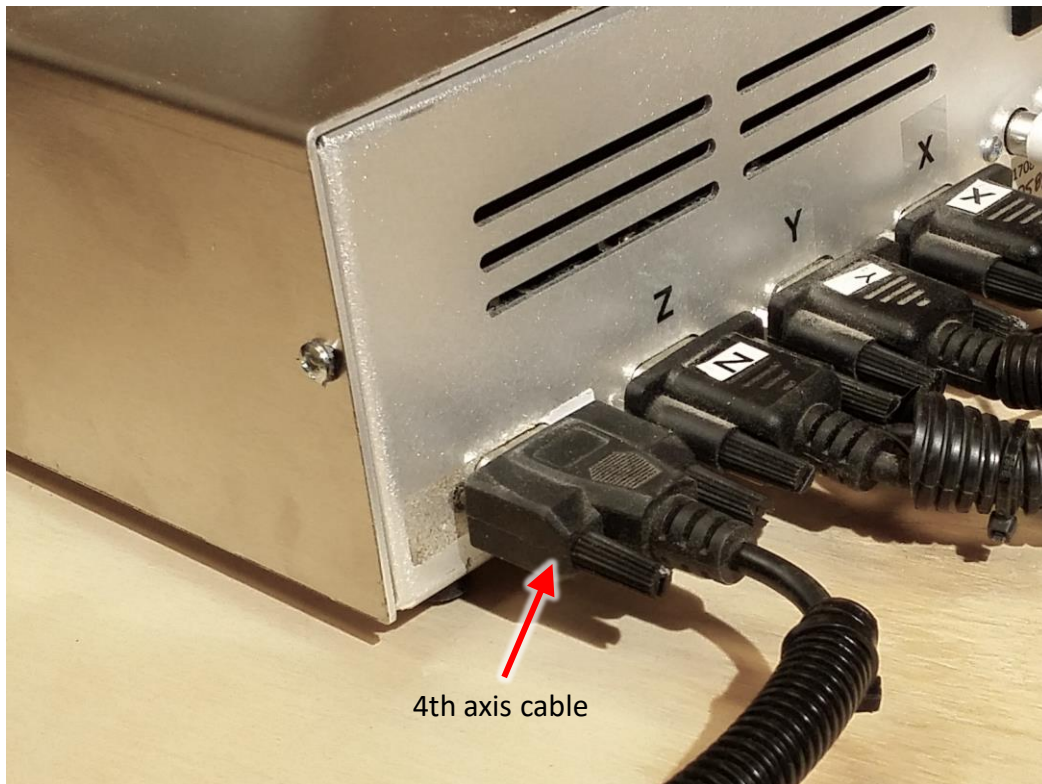

Step 11 – Attach 4th axis cable to the new port. Also attach any remaining cables.

Standard 4th Axis Pendant Setup

To operate a 4th axis on a CNC Shark you need to select the correct 4th Axis settings on the pendant.

Step 1 – Power the unit on and go to the **Apps** screen

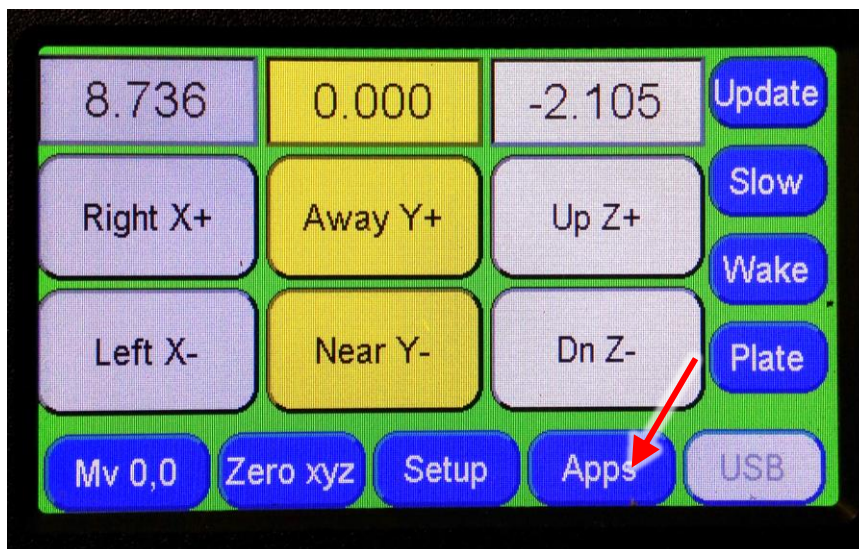

Step 2 – Use the scroll arrow at the bottom to scroll down until you reach **4th Axis**. Select **4th Axis** in the menu and then **Press to Open**

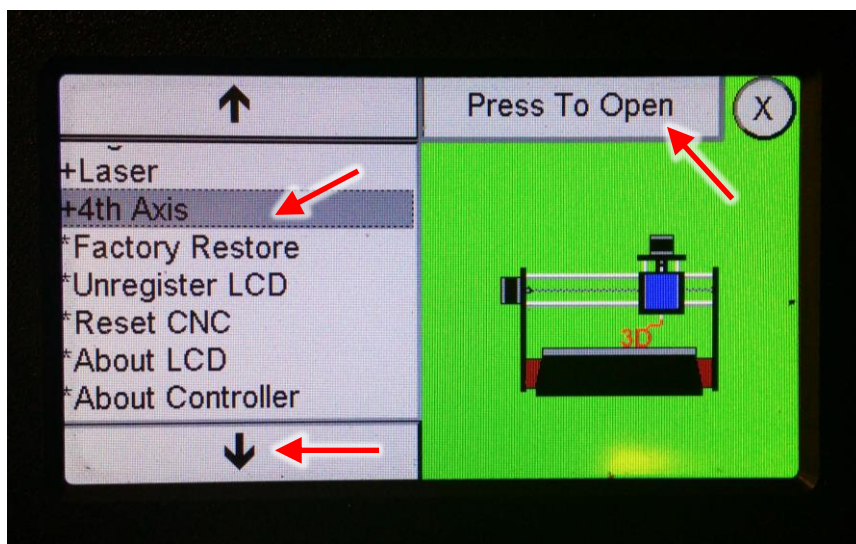

Step 3 – Select **3D Mode** in the left menu.

If the settings field at the top right shows **"0=OFF"** then skip to Step 5 on the next page.

If the settings field does not show "0=OFF" then press on the settings field to open the keypad and proceed to Step 4.

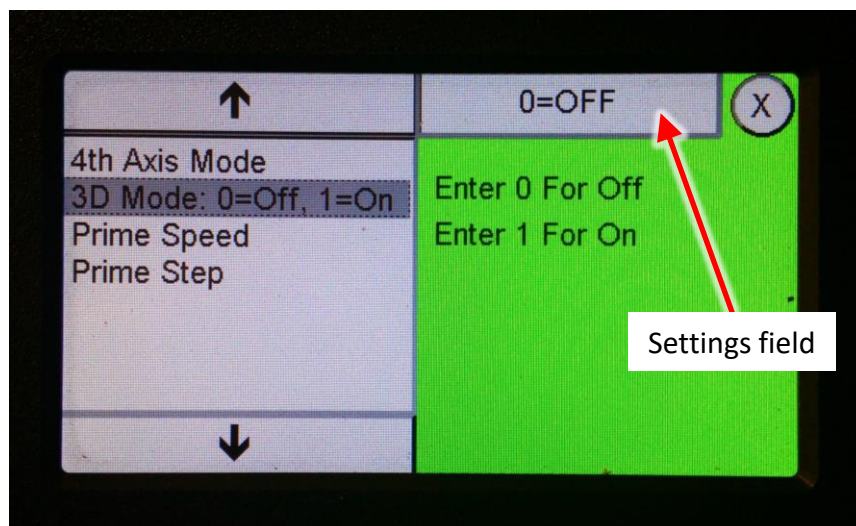

Step 4 – Press **0** on the keypad for "OFF" and then Press OK to save the change and exit the keypad.

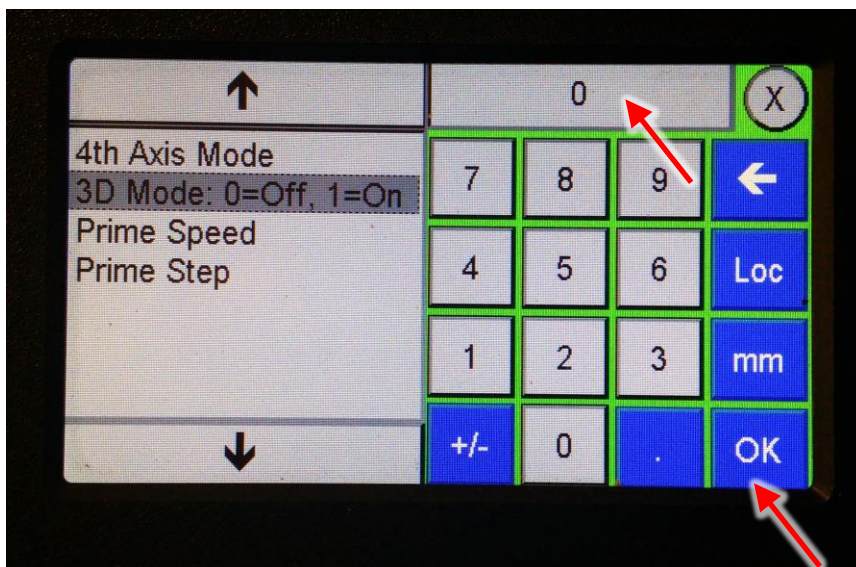

Step 5 – Select "4th Axis" in the menu and then "Press to Open."

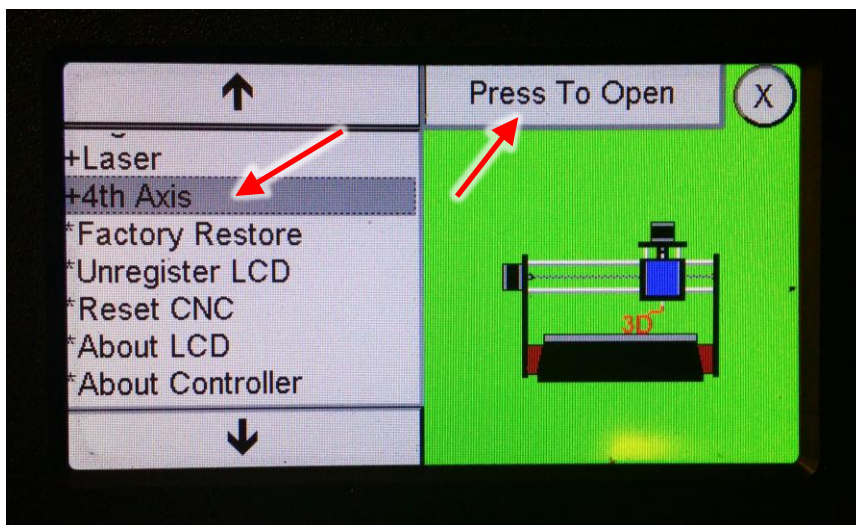

Step 6 – Select **4th Axis Mode** in the left menu. If the settings field at the top right shows "**2=Lathe Type A**" skip to Step 8. If the settings field does not show "2=Lathe Type A", then press on the settings field to open the keypad and proceed to Step 7.

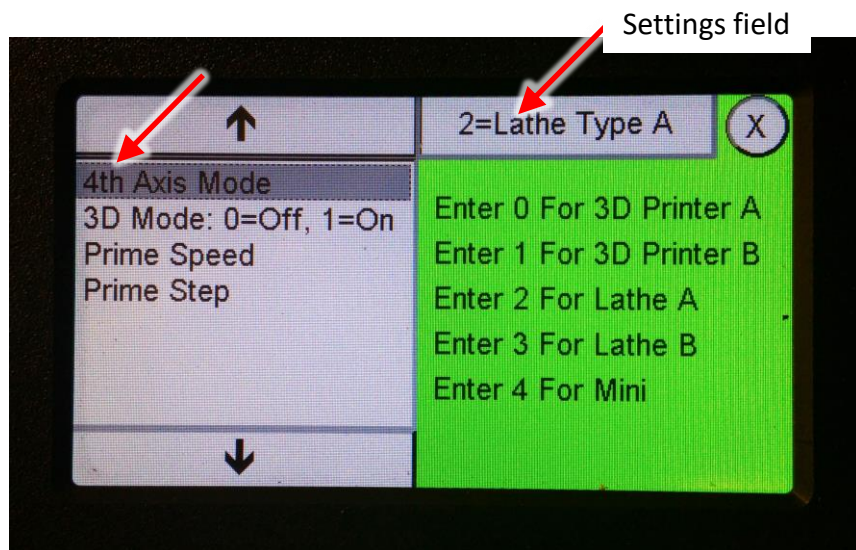

Step 7 – Use the keypad and enter the number "2". Then press **OK**.

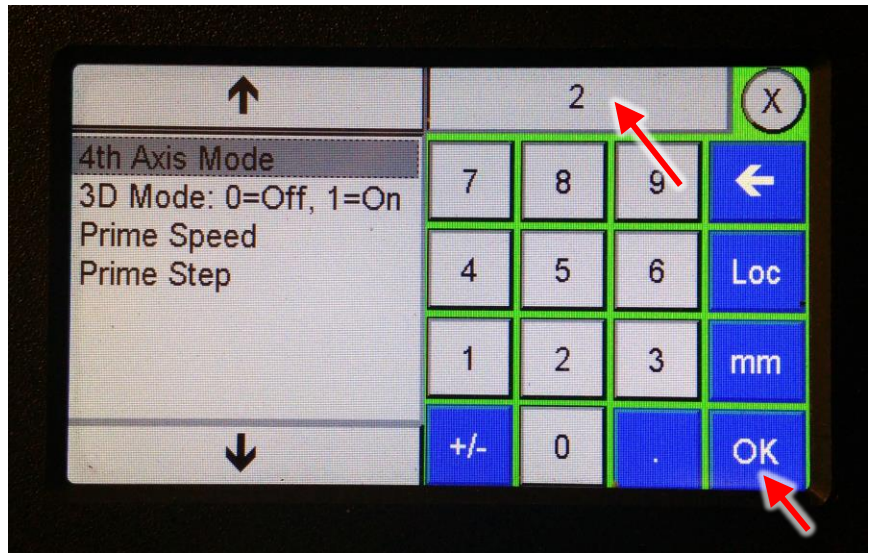

Step 8 – The settings field should now show **2=Lathe Type A**. Press the **X** in the upper right to exit the setup screen.

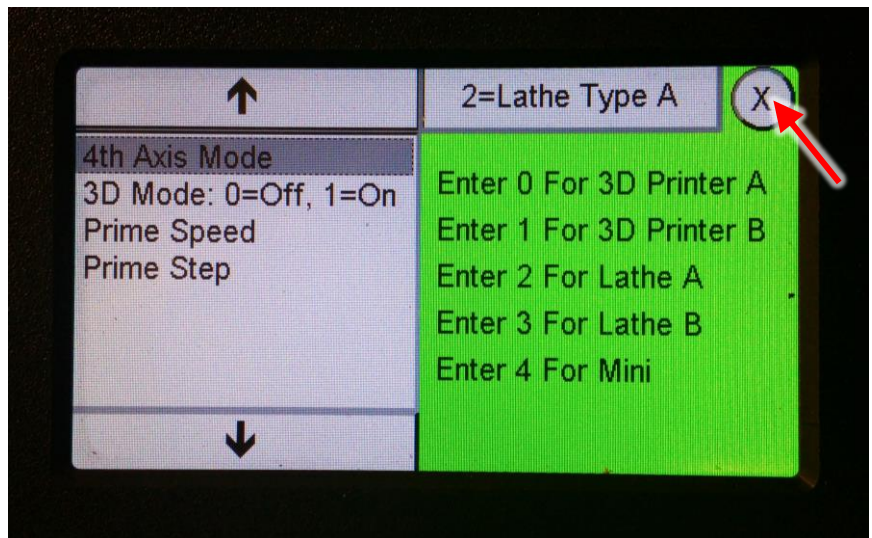

Step 9 – Pendant setup for the Standard 4th Axis is now complete.

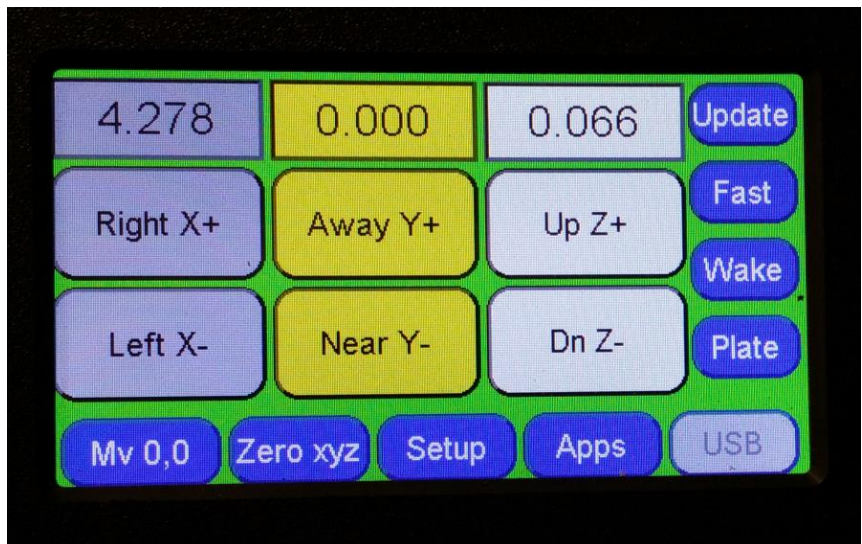

Mounting the 4-jaw Chuck (Standard 4th Axis)

This step is similar to mounting a jaw chuck on a lathe except for a couple steps, which are outlined below.

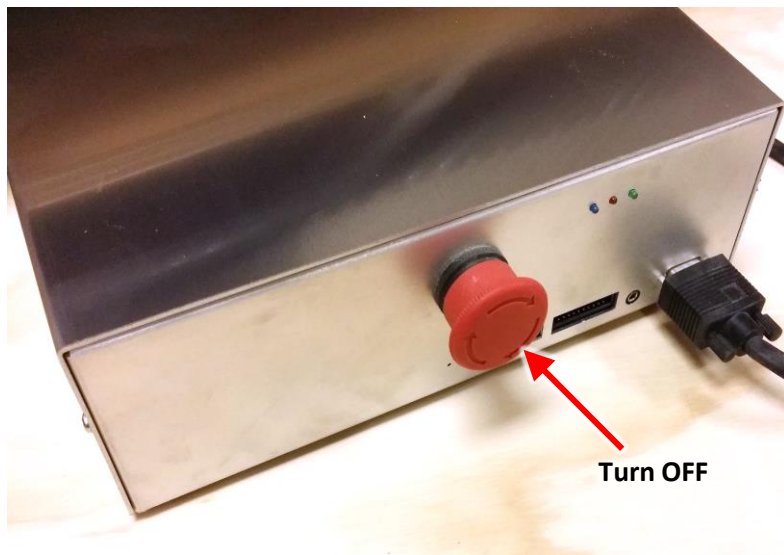

Step 1 – Turn off the control box.

Step 2 - Align the chuck with the threaded drive shaft and hand tighten.

Step 3 – Put a screw driver in one of the holes in headstock slip-ring and one of the chuck rods in one of the holes on the chuck head. Hold the screwdriver firm and rotate chuck rod until the chuck is tight.

(To remove the chuck, reverse the process)

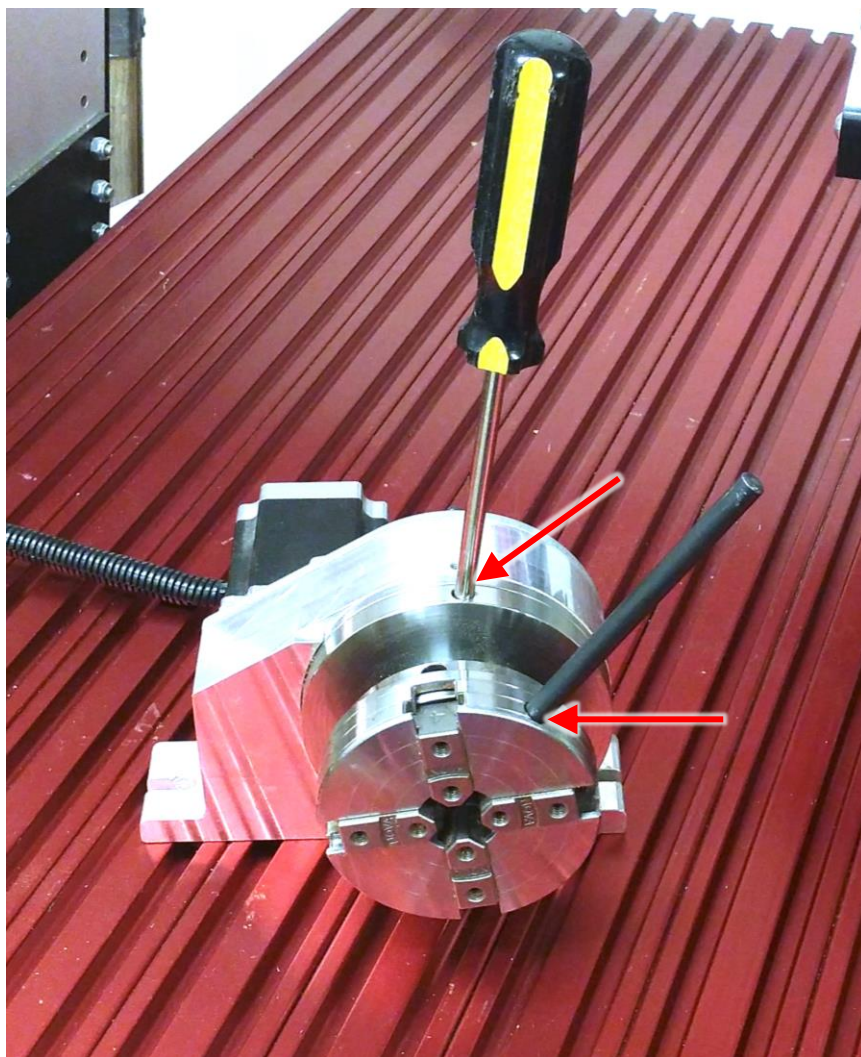

Check Gantry Height (Standard 4th Axis on CNC Shark)

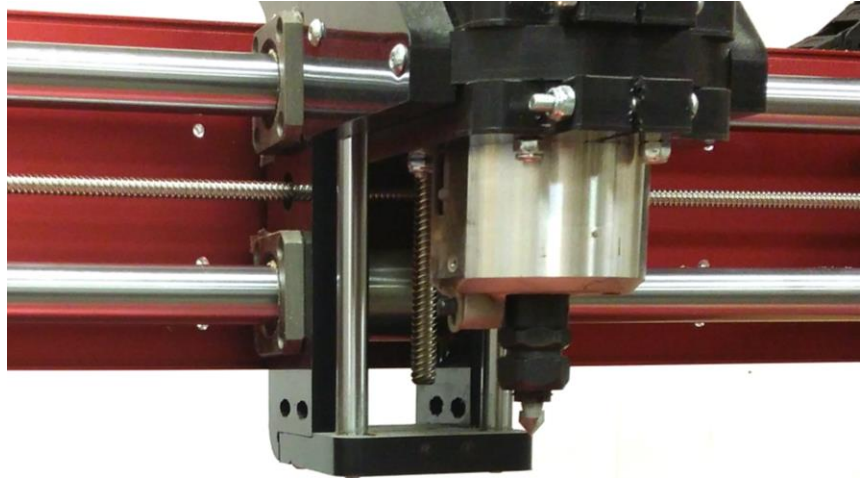

Clearance →

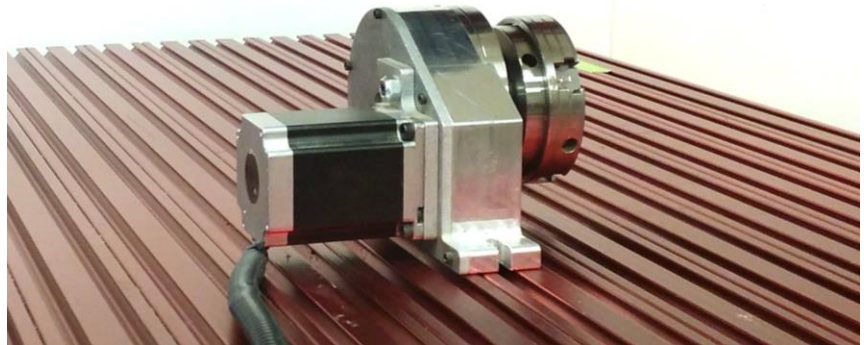

The bottom of the Shark XZ car needs to clear the top of the headstock.
It only has to be high enough to clear the headstock.

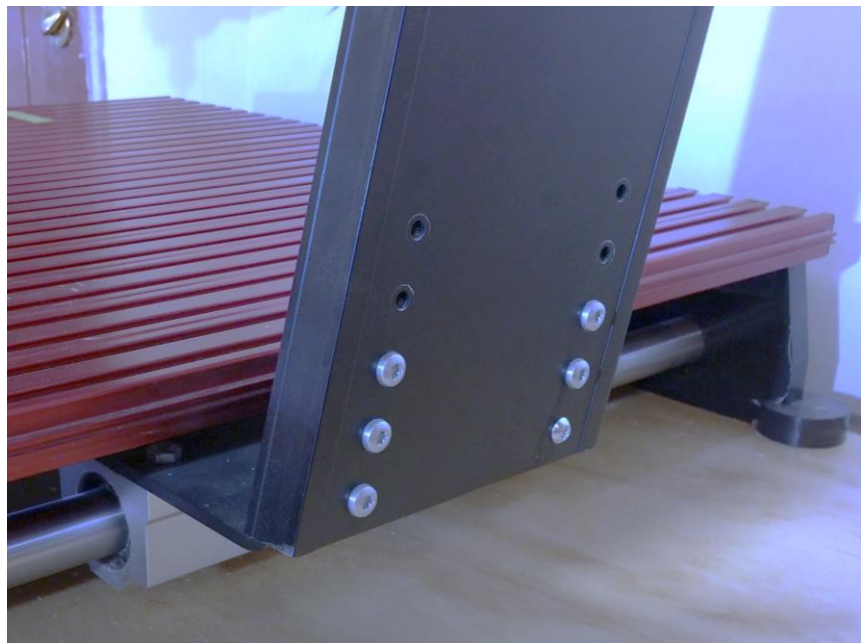

Raise the Shark gantry sides as needed to achieve the necessary clearance.

Standard 4th Axis Mounting Options

The Standard 4th Axis can be mounted either "Along the X Axis" or "Along the Y Axis". "Along the Y" provides a couple more inches of length, but general performance is the same in either direction.

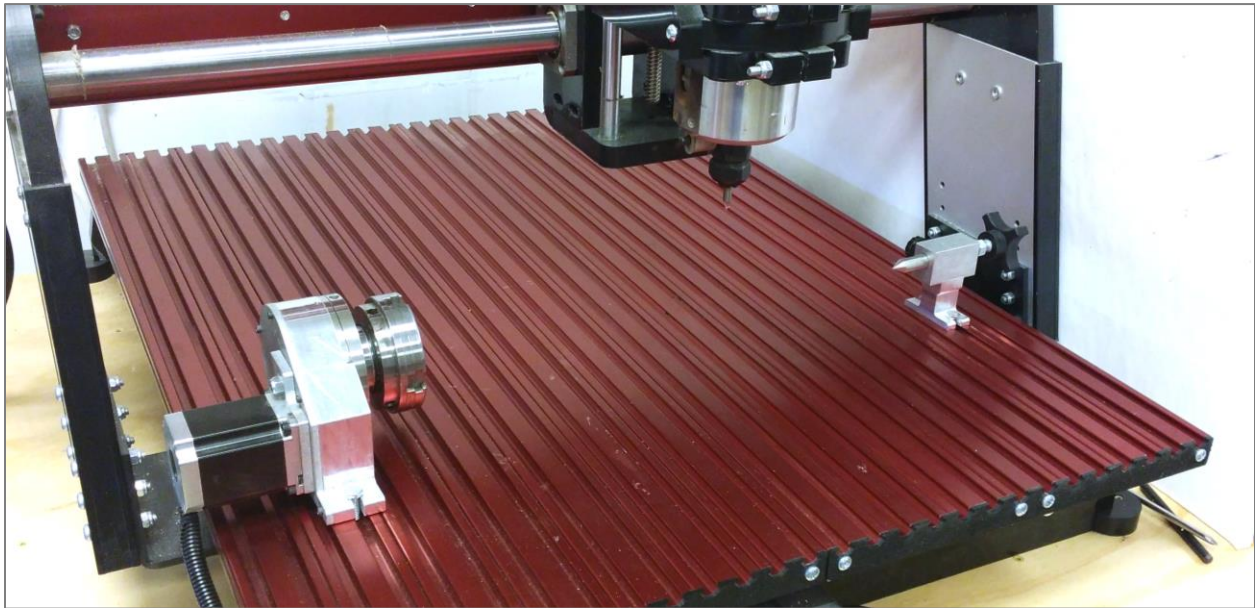

This picture shows the Standard 4th Axis installed "**Along X Axis**". The headstock should be mounted on the left side of the machine with the tailstock on the right side. Make sure the headstock and tailstock clear the gantry supports. The head and tail stocks can be mounted closer to each other to accommodate shorter stock.

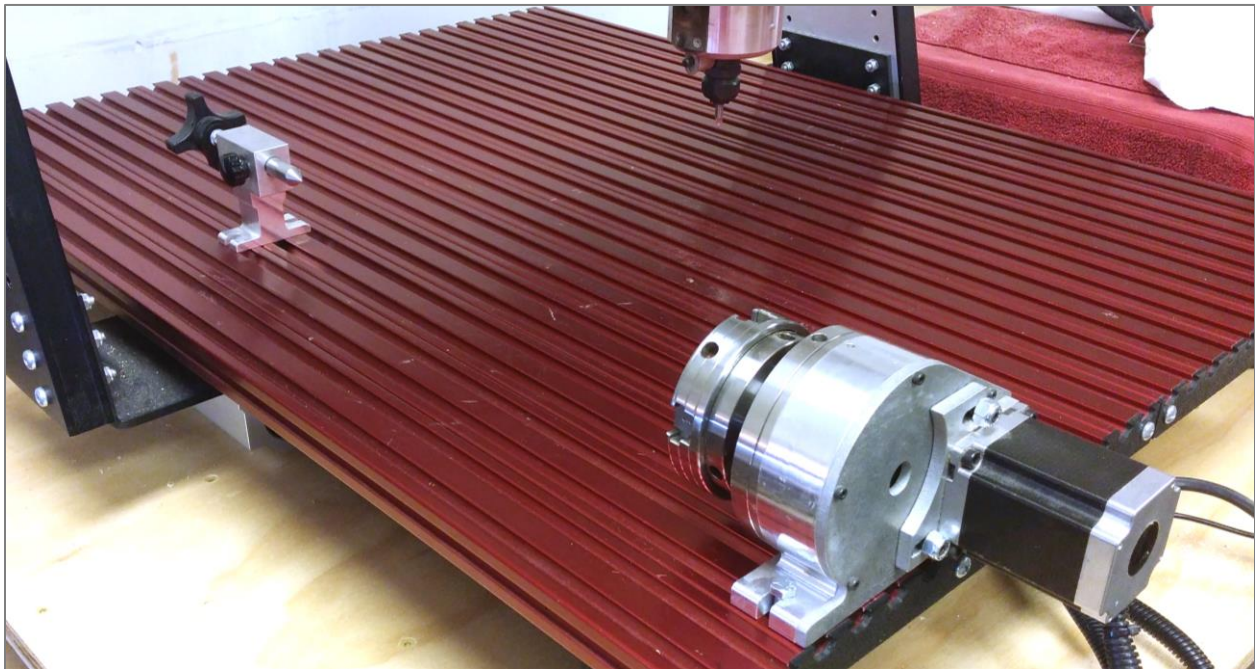

This picture shows the Standard 4th Axis installed "**Along Y Axis**". The headstock should be mounted at the front of the machine with the tailstock on the back. The head and tail stocks can be mounted closer to each other to accommodate shorter stock.

Headstock and Tailstock Alignment process for the Standard 4th Axis.

The head and tail stocks must be aligned with each other and to the router bit in order to achieve the best cutting results. There are several ways to achieve this alignment. The one shown here provides one way, but you may discover another way as you work with your machine. Feel free to use the method that works best for you.



Step 1 – The first thing to consider is that the rotary workpiece (stock) must be positioned within the cutting area of your machine. One way to identify this area is to jog the gantry (with a v-bit installed) to each corner of the table and mark the cutting area (travel limits less about .25") with tape or a marker.

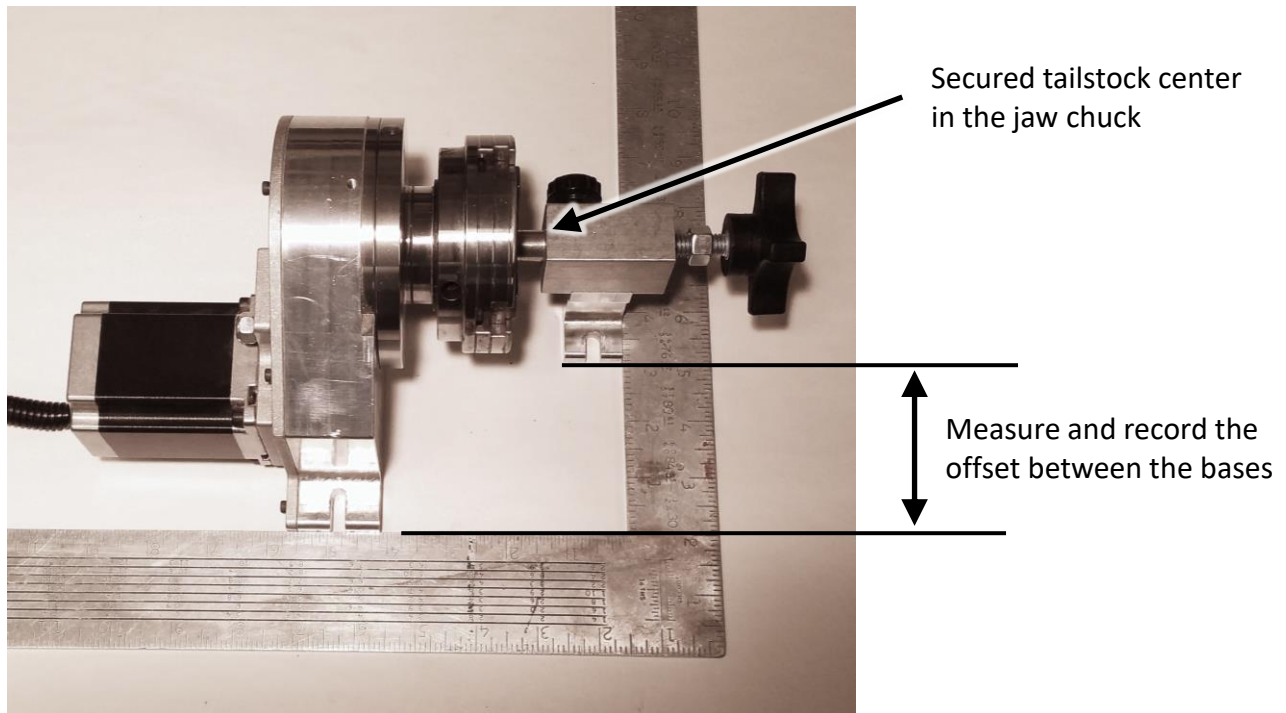

Step 2 – Next lightly clamp the tailstock center inside the jaw chuck. Then measure the offset between the bases. Record this measurement for future use.

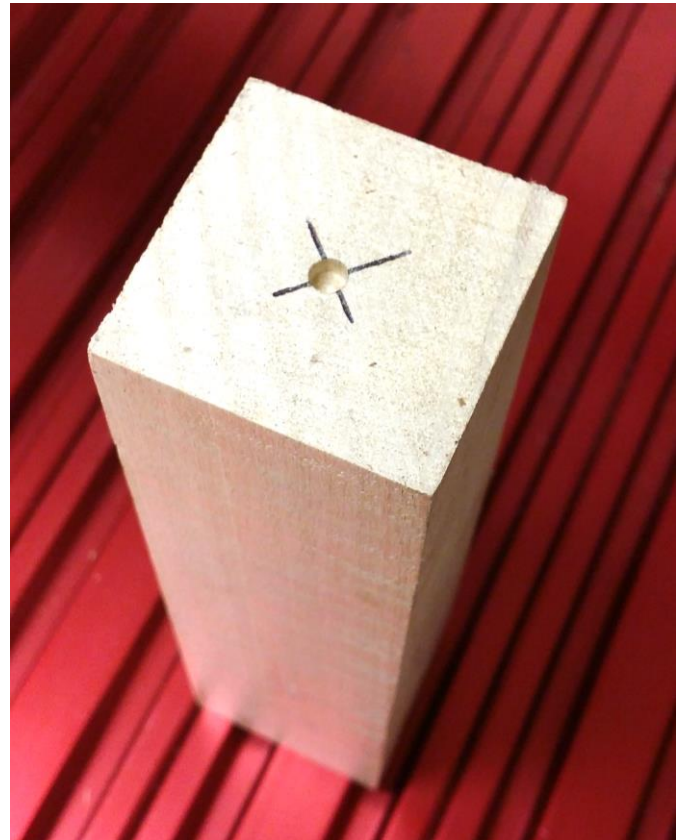

Step 3 – Drill a small hole (1/8" to 1/4" dia.) in the tailstock end of your workpiece.

Make the hole deep enough so the point of the tailstock center does not hit the bottom.

TIP:
Rub some wax in the tail center hole to reduce friction and squeaking.

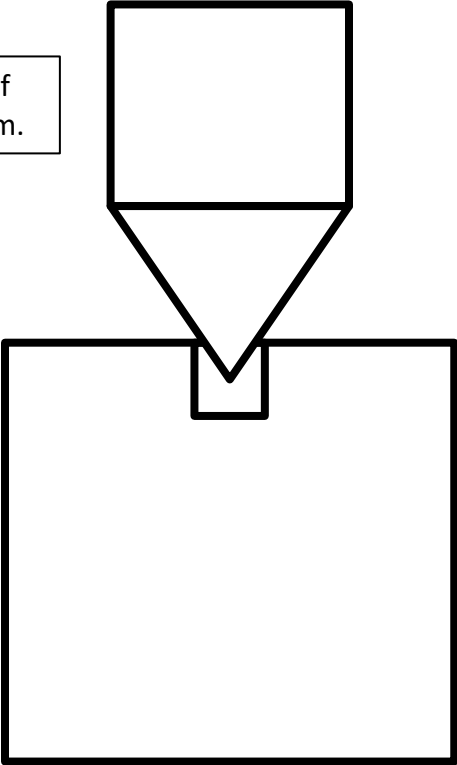

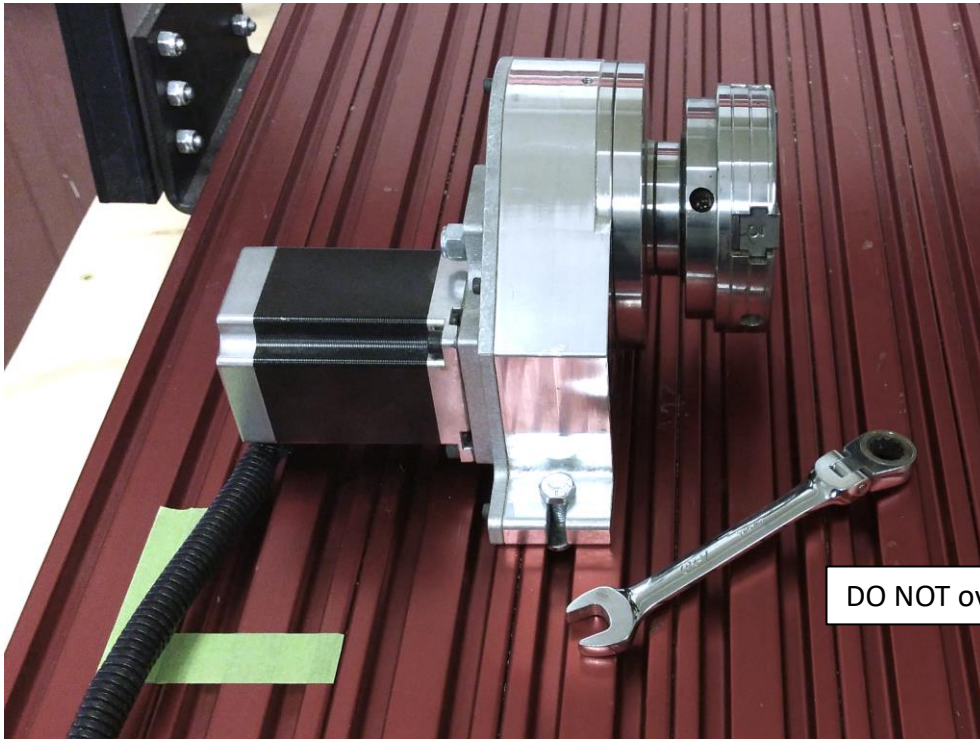

Step 4 – Secure the headstock to the table using the bolts and T-slot nuts. Firmly snug bolts. This picture is for an "Along the X" setup. When installing "Along the Y" use a framing square to ensure the headstock is square to the table.

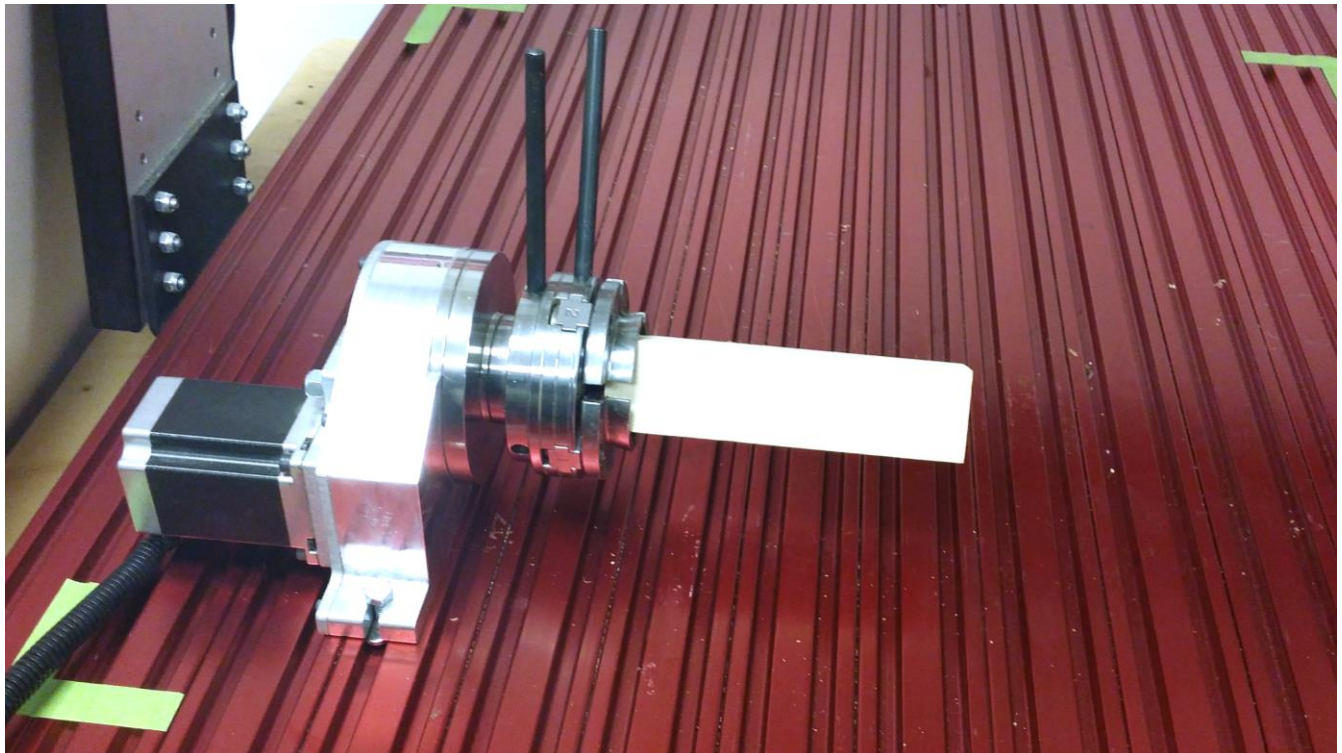

Step 5 – Lightly mount the workpiece in the headstock.

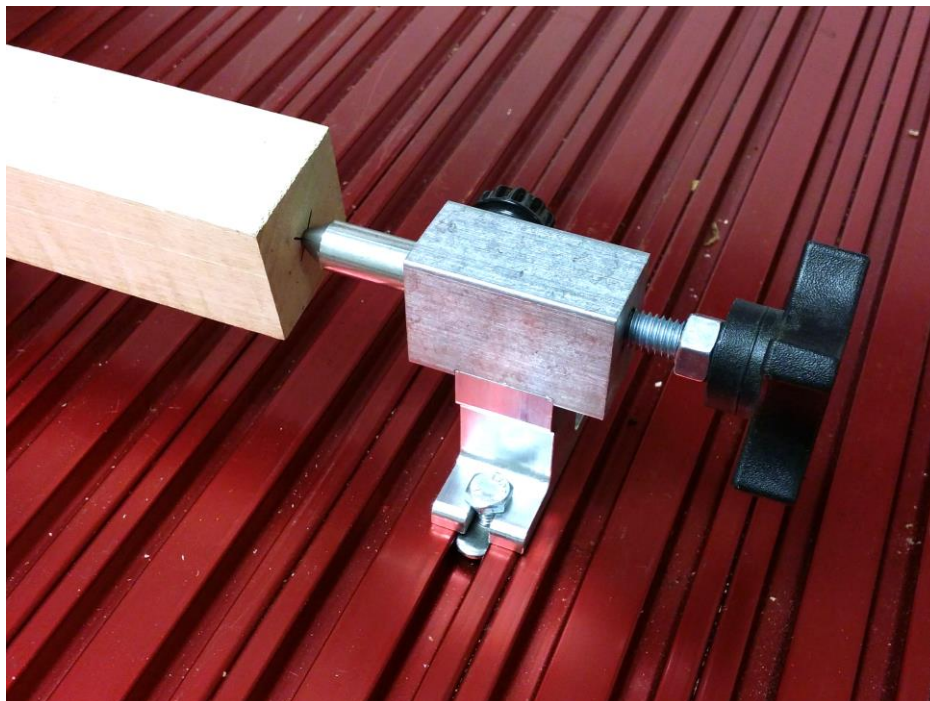

Step 6 – Slide the tailstock up to the small hole in the end of the workpiece. This provides the approximate spacing between the head and tail stocks. Make sure there is enough travel distance in the tailstock center so it can be tightened against the workpiece after the tailstock is secured to the table.

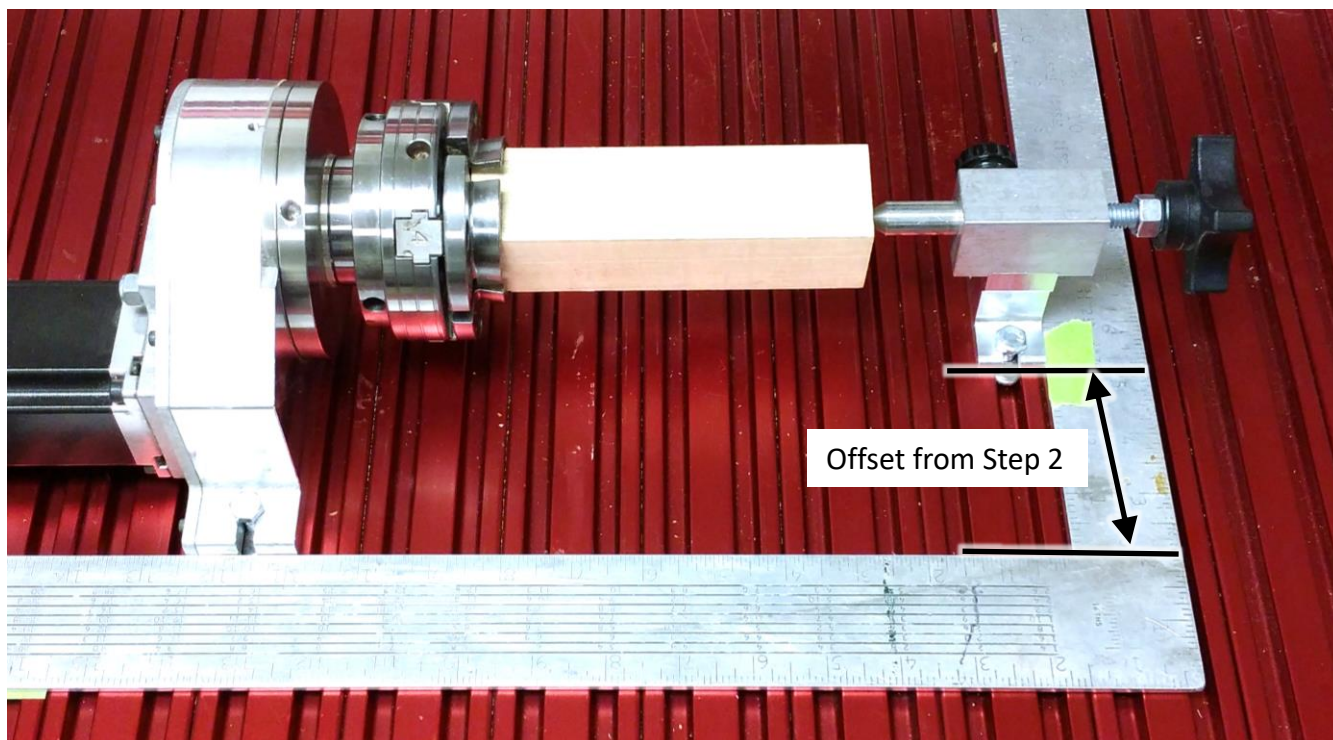

Step 7 – Square the tailstock to the headstock using a framing square. Offset by the distance measured in Step 2. At this time, only finger tighten the bolts in the tailstock base. They will be fully tightened later.

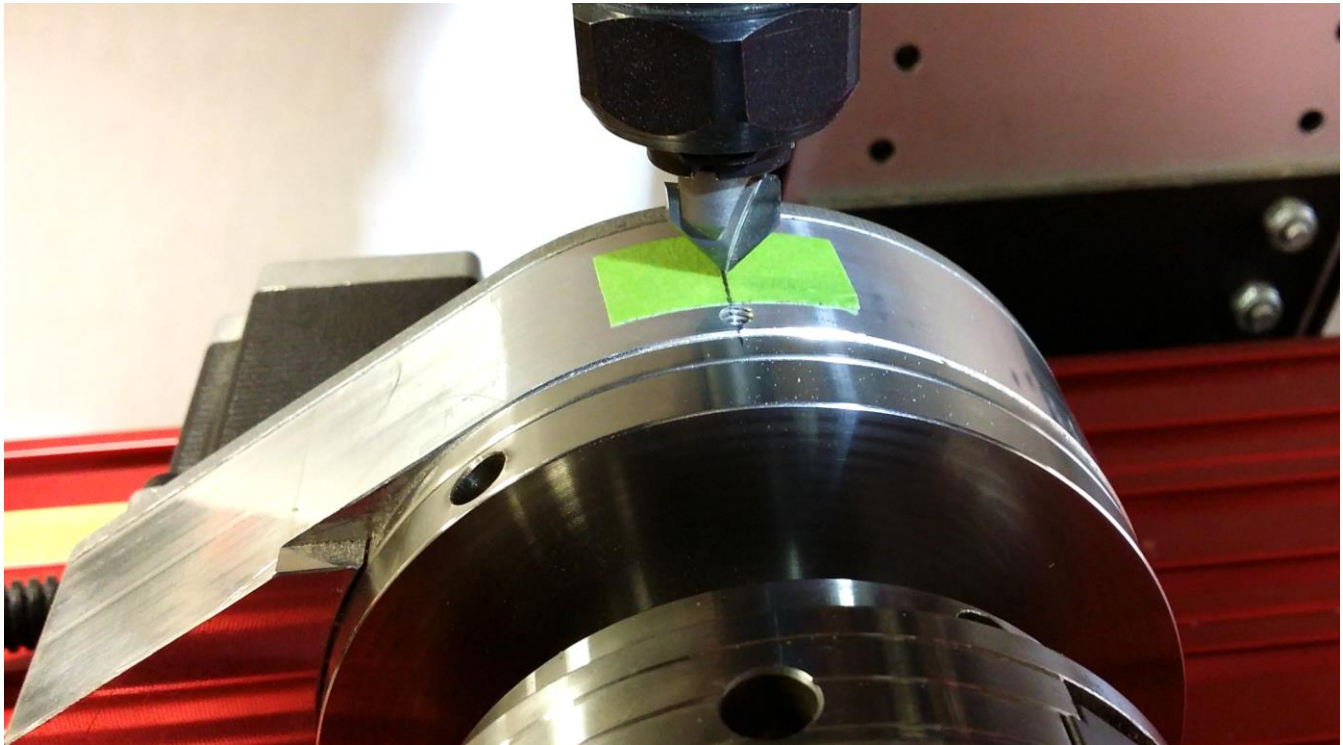

Step 8 – Put a v-bit in the collet and jog the bit to the top and center of the Headstock. A small line drawn on a piece of tape simplifies this step.

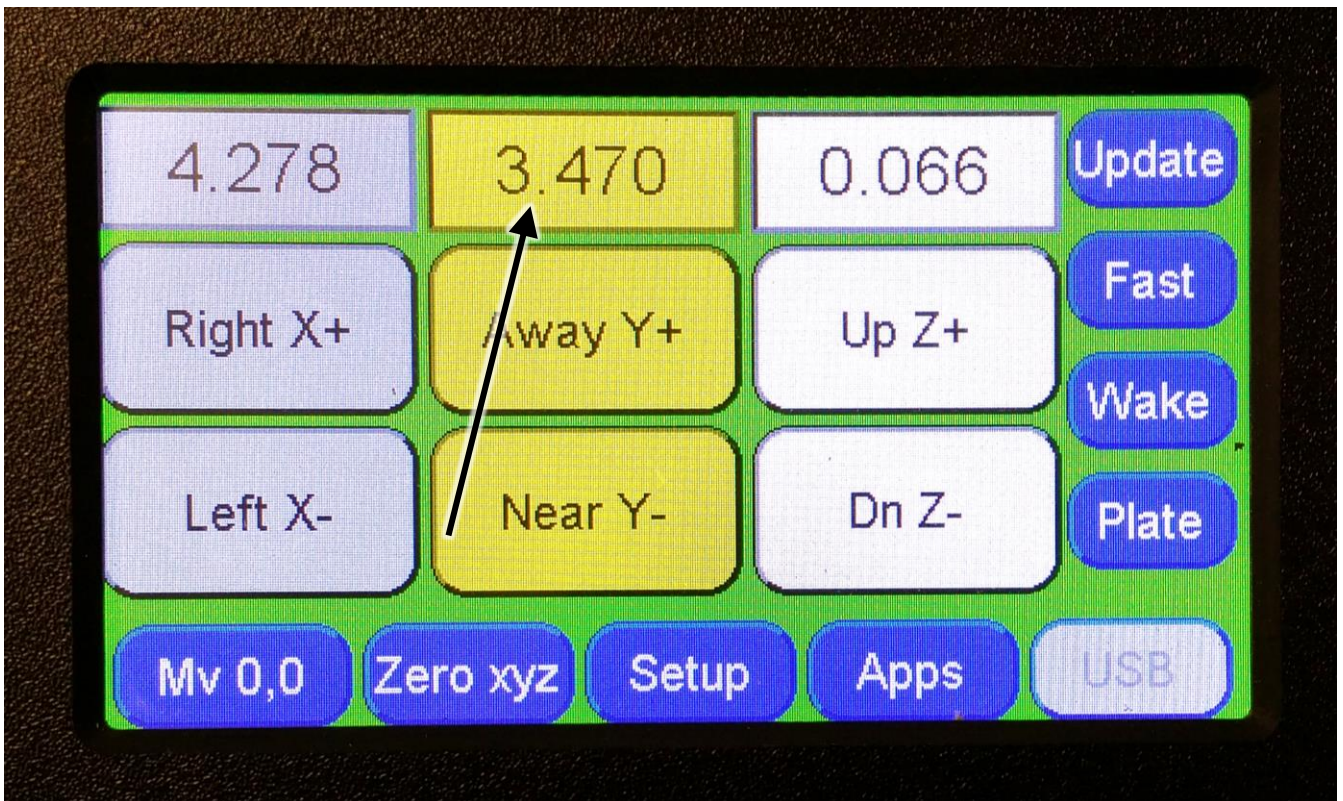

Step 9 – Press position field above the Y entry. This will open the Y axis keypad window

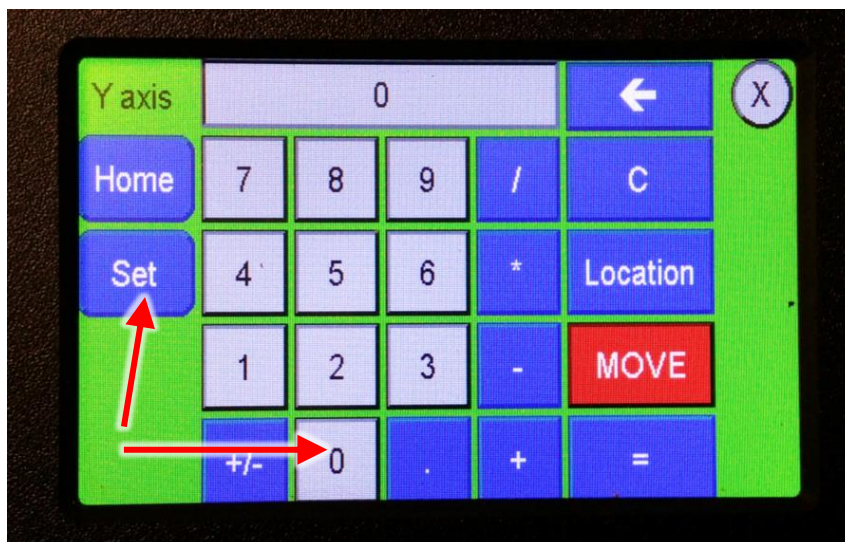

Step 10 – Enter **0**, and then **Set** to accept change.

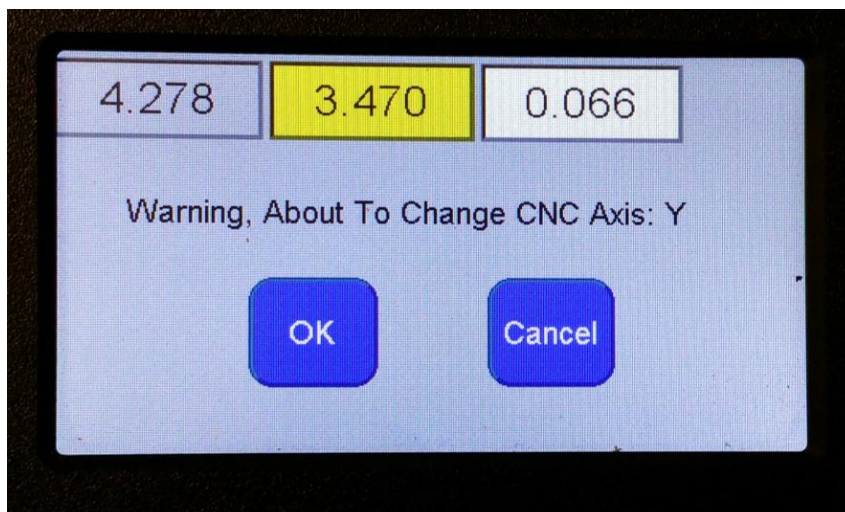

Step 11 – Press **OK** to finalize change.

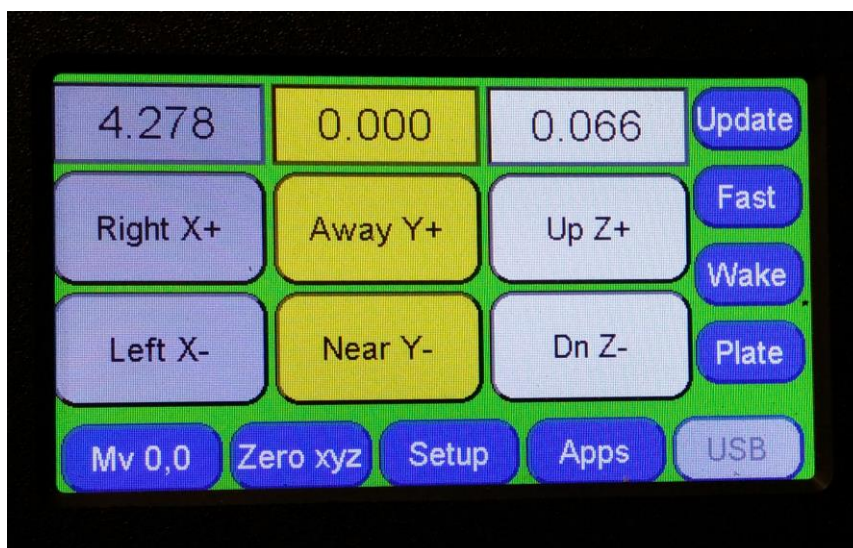

Step 12 – The Y axis is now zeroed to the center of the headstock.

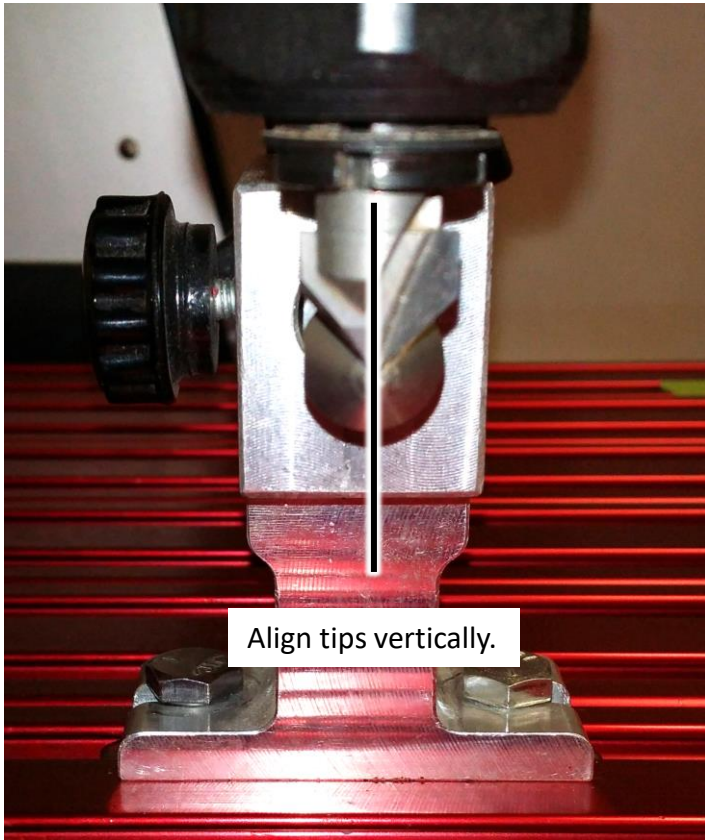

Step 13 – Jog the v-bit over the tailstock center. Adjust the location of the tailstock as needed so the points align vertically. Then tighten the tailstock mounting bolts.

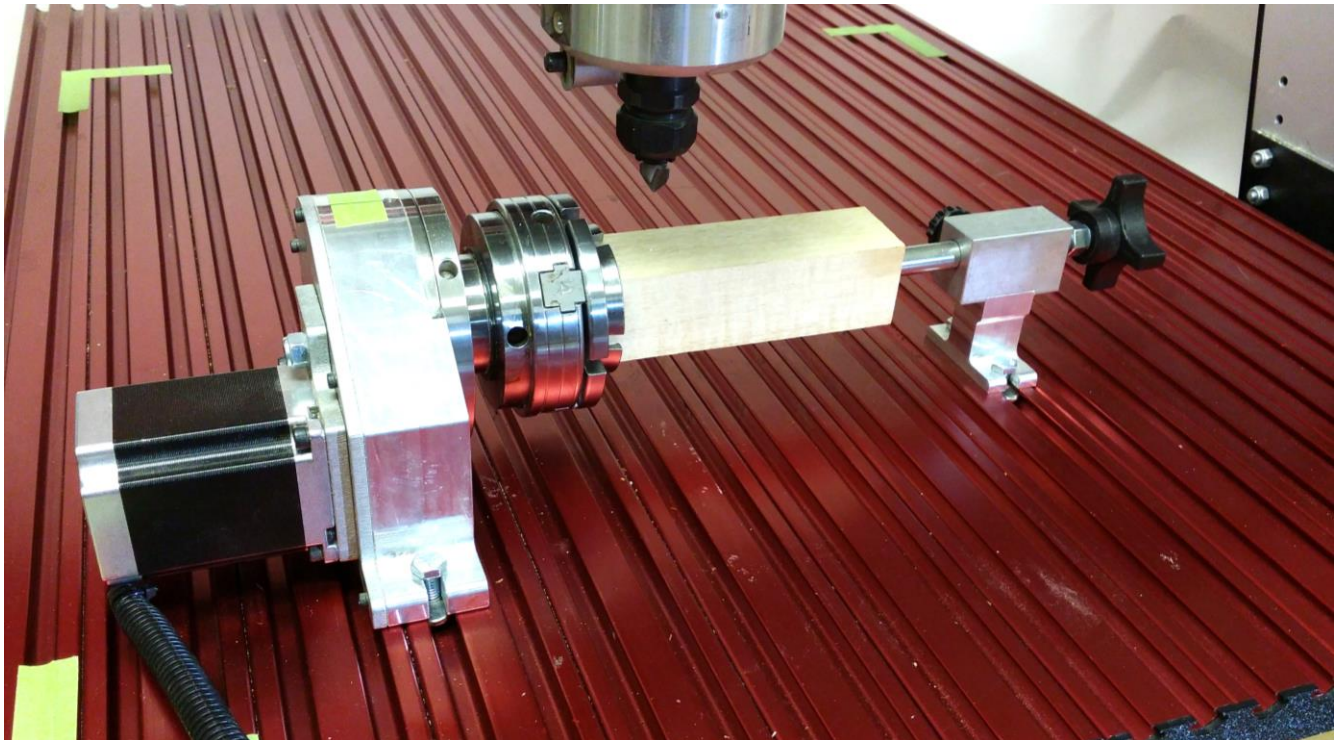

Step 14 – The headstock and tailstock are now mounted and aligned. Reinstall the material, tighten the jaws, and set tailstock center so it's snug in the drilled hole. You are almost ready to start machining. See page 42 for step-by-step instruction on creating and running a 4th axis toolpath file.

Mini 4th Axis Overview

The Mini 4th Axis gives you the ability to create small turned spindles, columns and "in-the round" 3D models. The Mini 4th Axis easily bolts to your existing Shark or Piranha table. The headstock has a standard #2 Morse taper drive shaft that allows you to attach a variety of lathe accessories. The Mini 4th Axis comes with a precision 3-jaw chuck. This manual assumes you currently own a CNCShark or CNCPiranha as well as Vectric VCarve or Aspire software and are familiar with their operation.

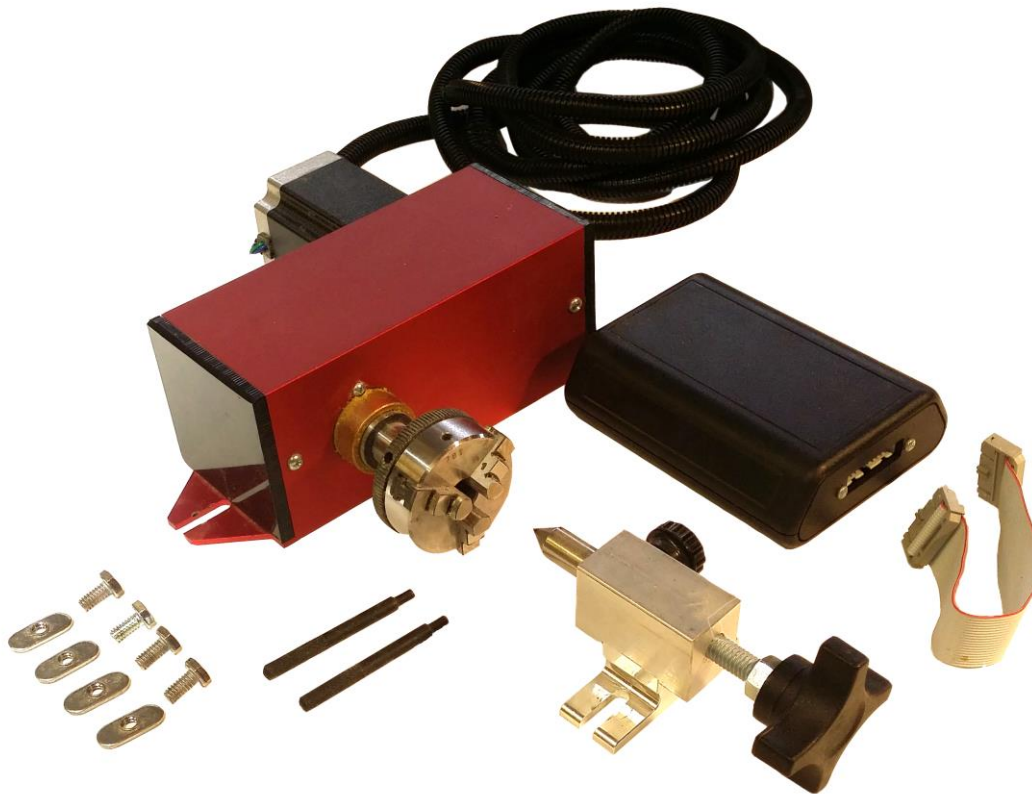

The Mini 4th Axis Accessory kit comes with the motorized headstock, 3-jaw chuck, adjustable tail stock, mounting hardware and interface hub.

Mini 4th Axis Pendant Setup

To operate a 4th axis on a CNC Shark you need to select the correct 4th Axis settings on the pendant.

Step 1 – Power the unit on and go to the **Apps** screen

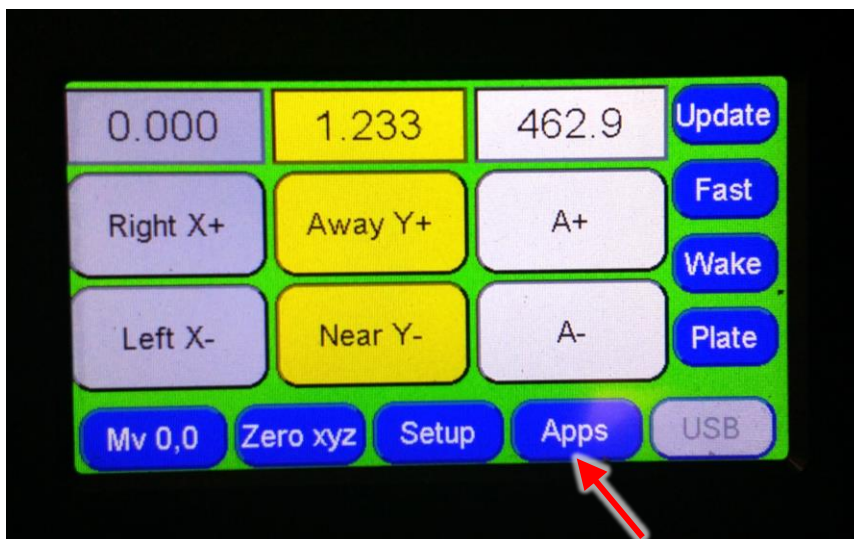

Step 2 – Use the scroll arrow at the bottom to scroll down until you reach **4th Axis**. Select **4th Axis** in the left menu and then **Press to Open**

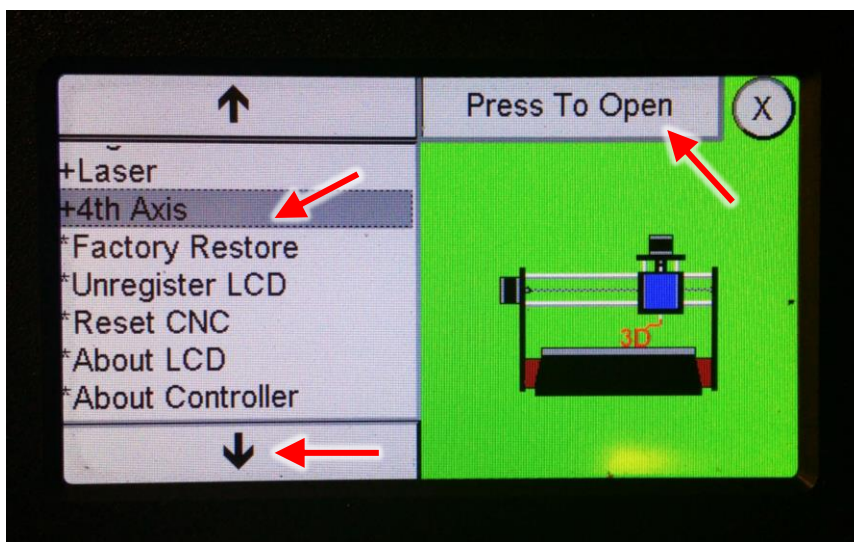

Step 3 – Select **3D Mode** in the left menu.

If the settings field at the top right shows **0=OFF** then skip to Step 5 on the next page.

If the field shows **1=ON** then press on the settings field to open the keypad and proceed to Step 4.

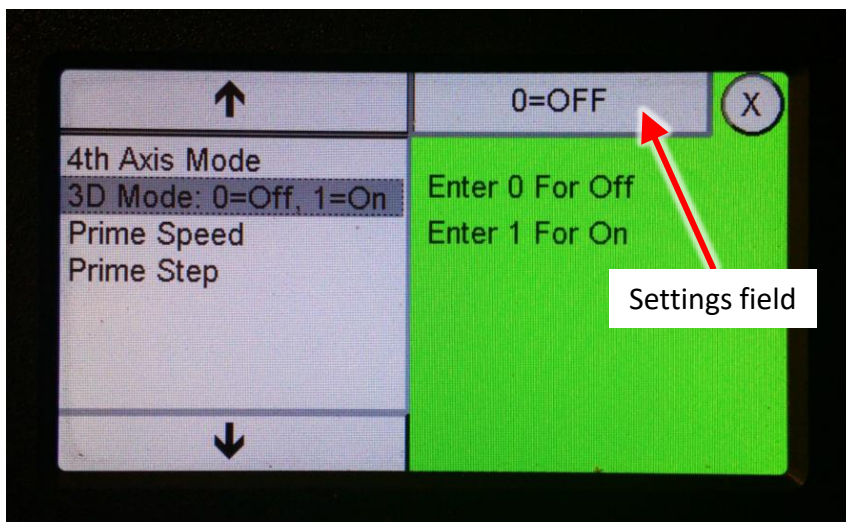

Step 4 – Press **0** on the keyboard for "OFF" and then Press **OK** to save the change and exit the keypad.

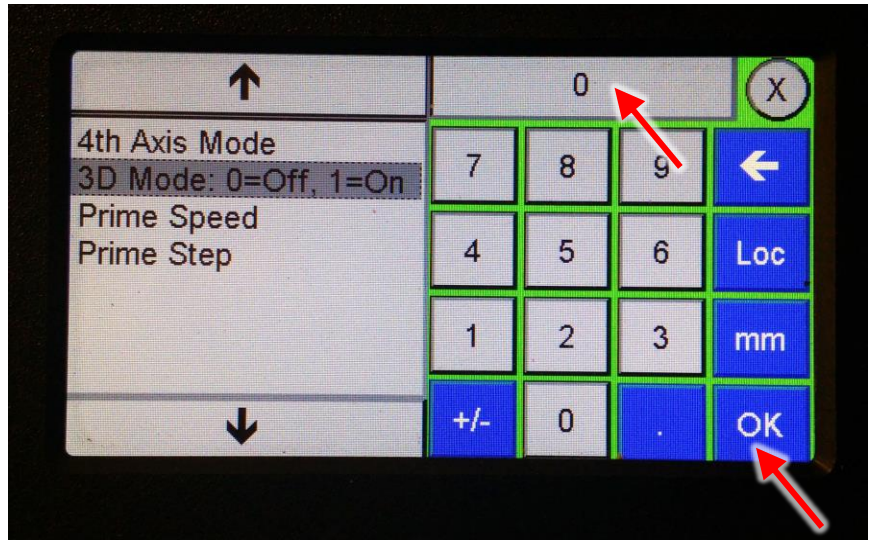

Step 5 – Select "**4th Axis**" in the left menu and then "**Press to Open.**"

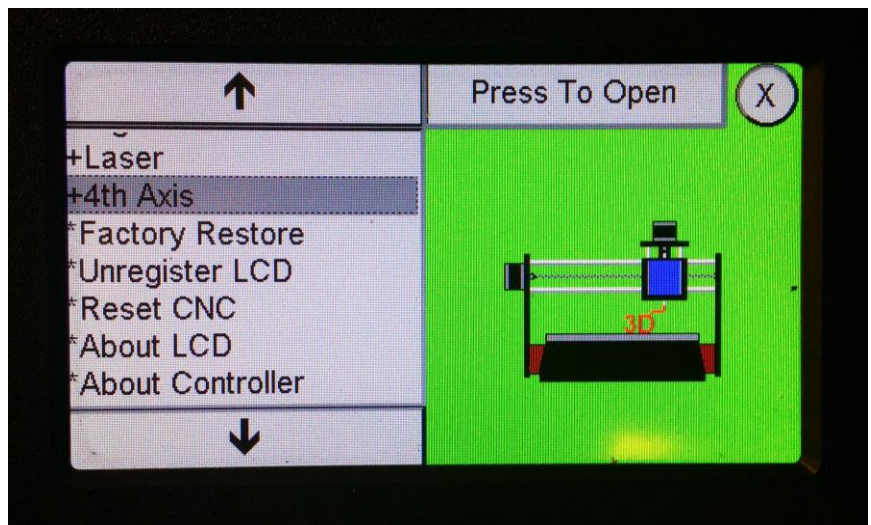

Step 6 – If the settings field at the top right shows "**4=Lathe Mini**" then skip to Step 8.

If the settings field does not show "4=Lathe Mini", then press on the settings field to open the keypad and proceed to Step 7.

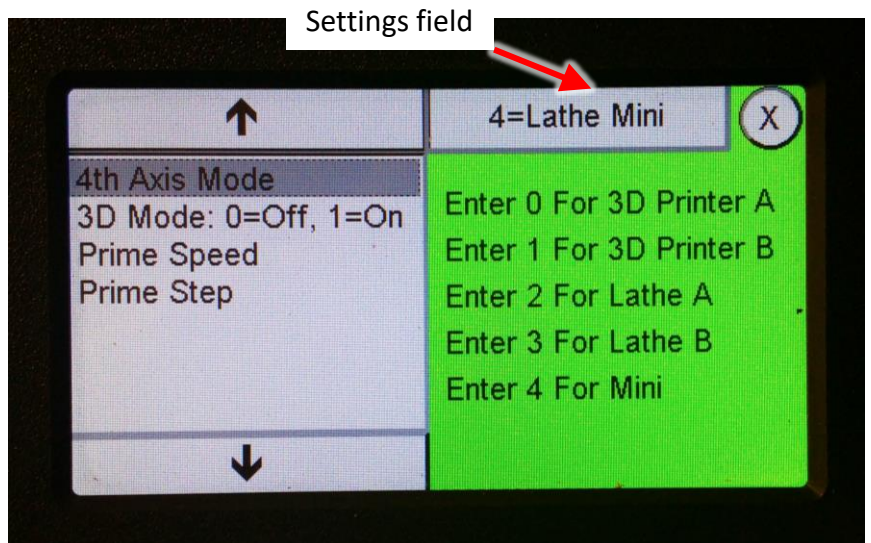

Step 7 – Use the keypad and enter the number 4. Then press OK.

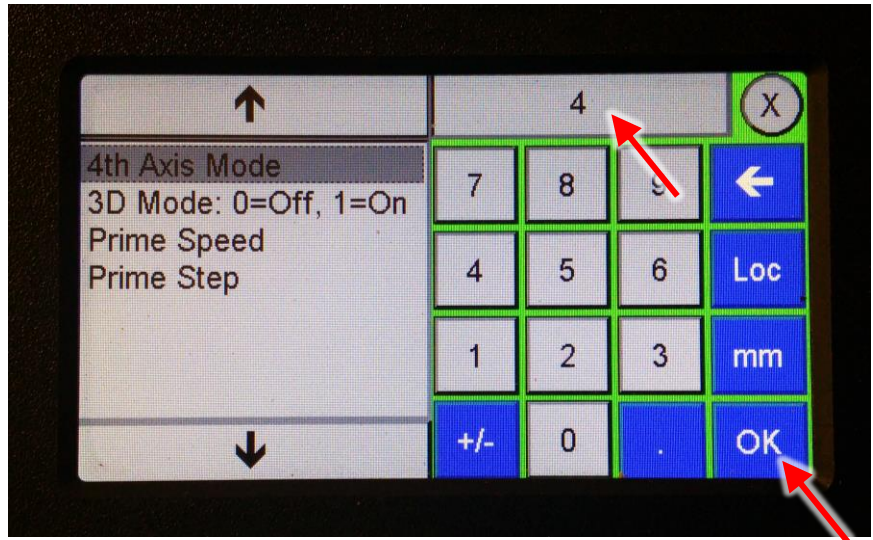

Step 8 – The settings field should now show 4=Lathe Mini. Press the X in the upper right to exit the setup screens.

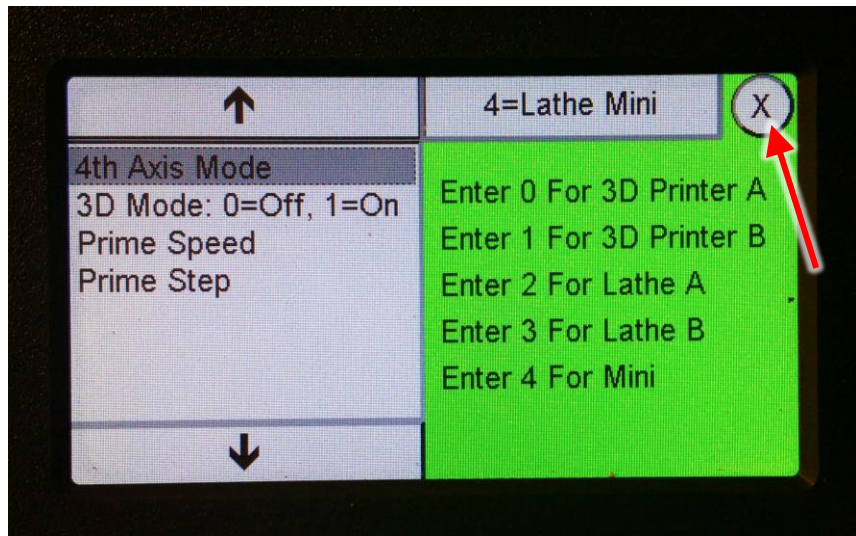

Step 9 –Pendant setup for the Mini 4th Axis is now complete.

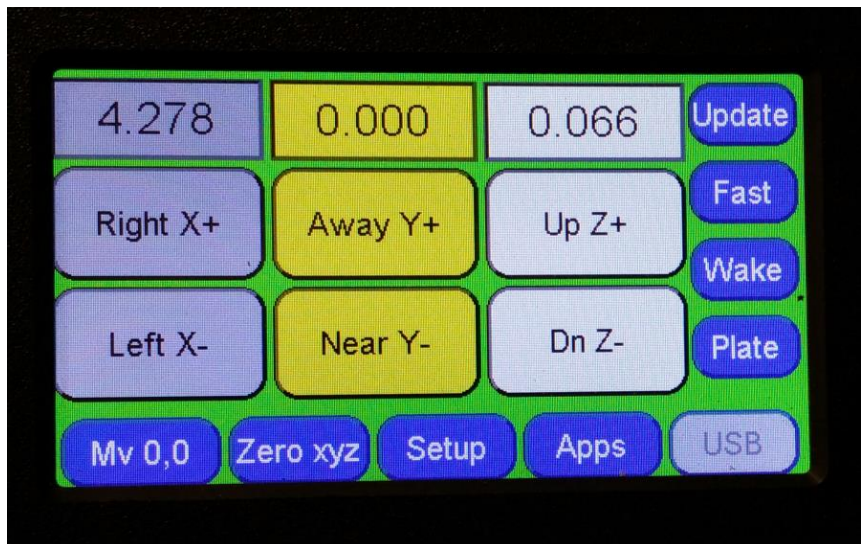

Mini 4th Axis Control Box hookup

CNCShark Control Box hookup

IMPORTANT

Turn power **OFF**
When connecting or disconnecting
motor or accessory cables

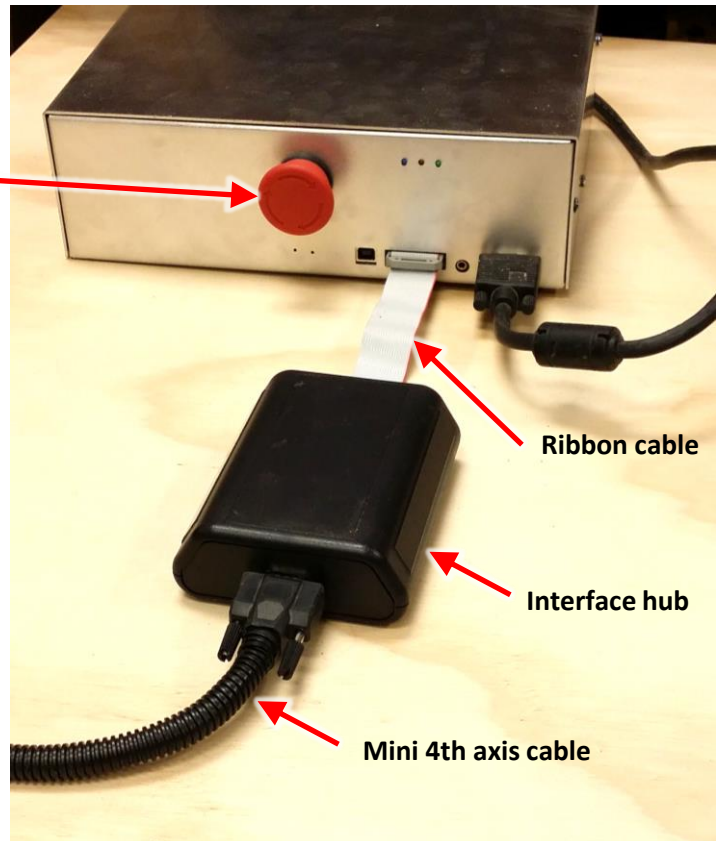

CNC Piranha Control box hookup

IMPORTANT

Turn power **OFF**
When connecting or disconnecting
motor or accessory cables

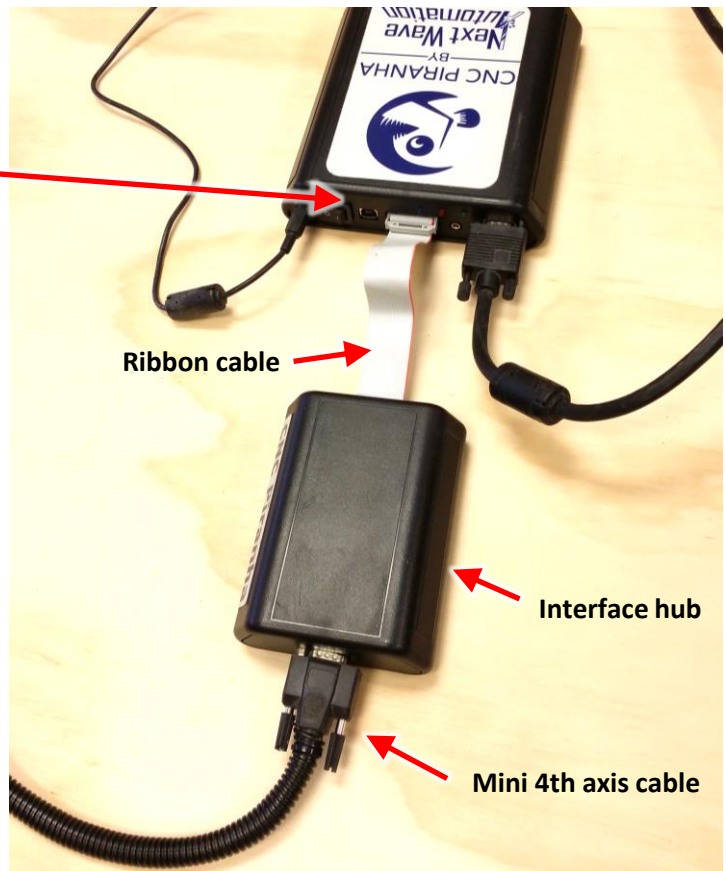

Mini 4th Axis Mounting Options

The Mini 4th Axis can be mounted on either "Along the X Axis" or "Along the Y Axis". "Along the Y" provides a couple more inches of length, but general performance is the same in both directions.

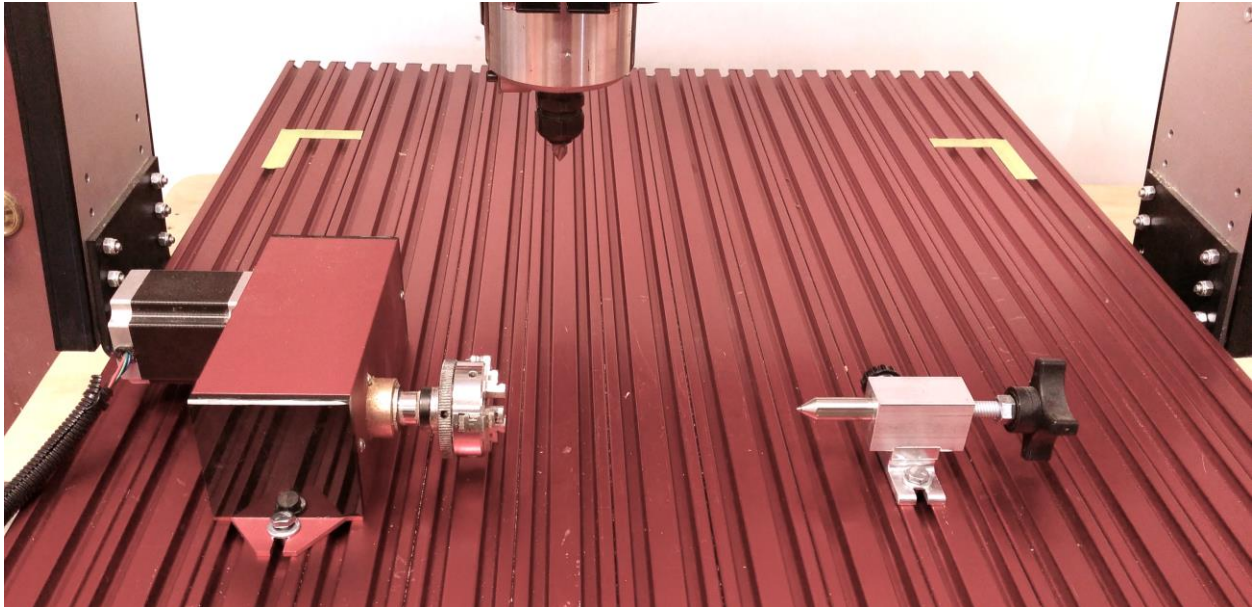

This picture shows Mini 4th Axis installed "**Along X Axis**". The headstock should be mounted on the left side of the machine with the tailstock on the right side. The head/tail stocks can be mounted closer or farther apart than shown. Make sure they clear the gantry supports.

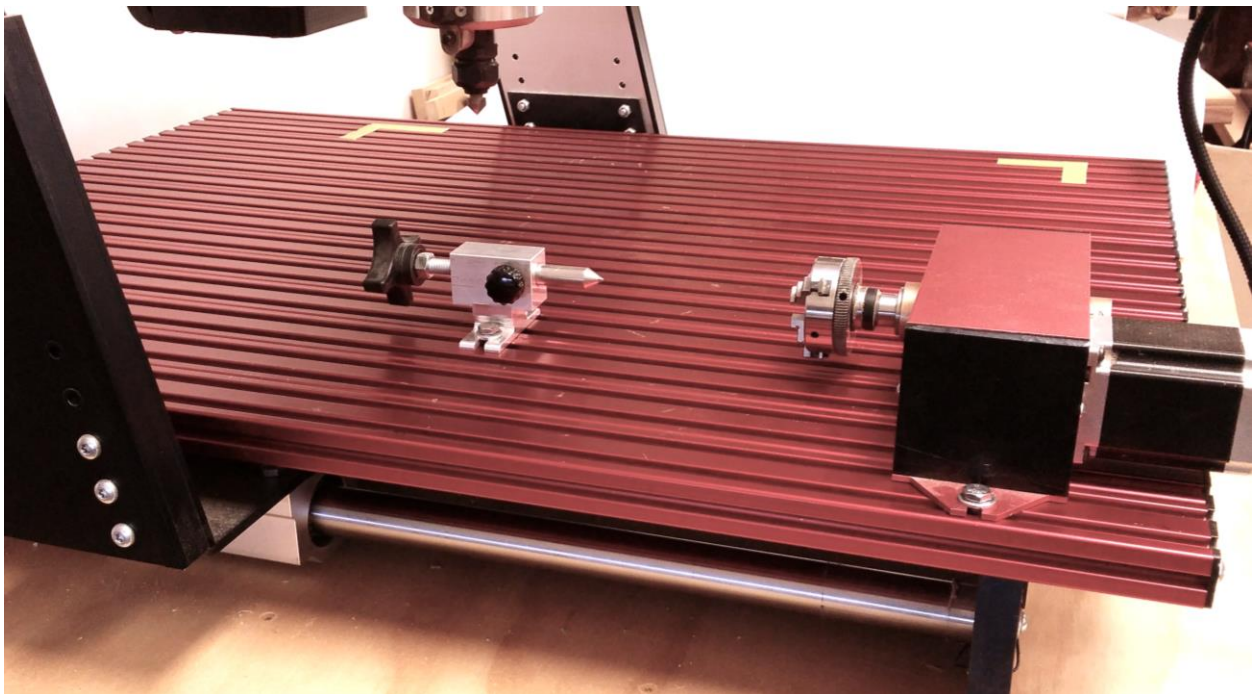

This picture shows Mini 4th Axis installed "**Along Y Axis**". The headstock should be mounted at the front of the machine with the tailstock at the back of the machine. The head/tail stocks can be mounted closer or farther apart than shown.

Mini 4th Axis Headstock and Tailstock Alignment process.

The head and tail stocks must be aligned with each other and to the router bit in order to achieve the best cutting results. There are several ways to achieve this alignment. The one shown here provides one way, but you may discover another way as you work with your machine. Feel free to use the method that works best for you.



Step 1 – The first thing to consider is that the rotary workpiece must be positioned within the cutting area of your machine. One way to identify this area is to jog the gantry (with a v-bit installed) to each corner of the table and mark the cutting area (travel limits less about .25") with tape or a marker.

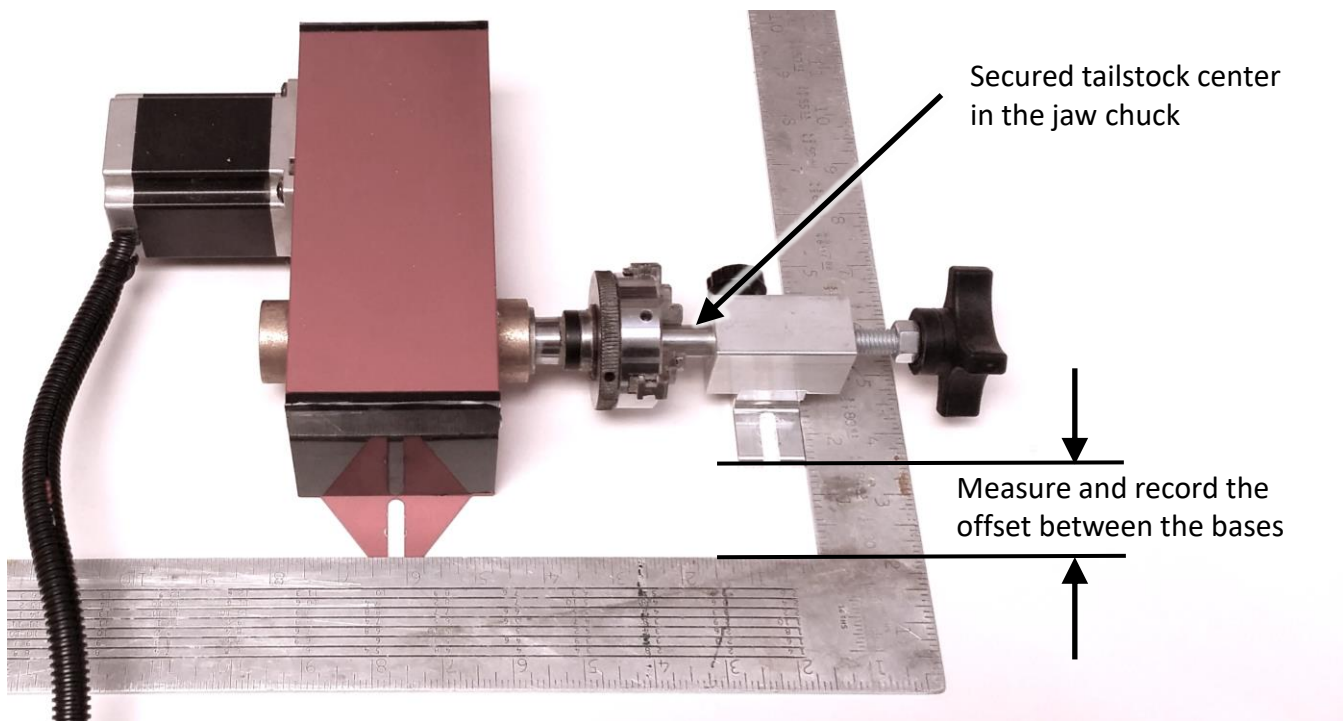

Step 2 – Next lightly clamp the tailstock center inside the jaw chuck. Then measure the offset between the bases. Record this measurement for future use.

Prep the tailstock end of your workpiece

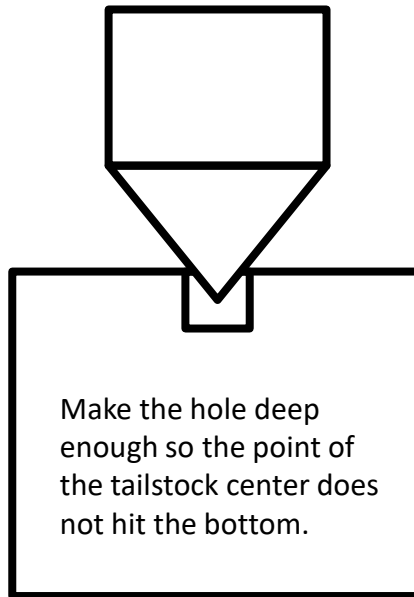
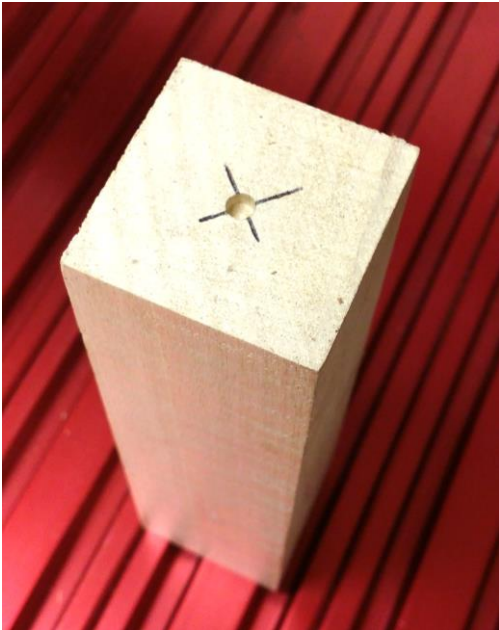

TIP:
Rub some wax in the tail center hole to reduce friction and squeaking.

Step 3 – Drill a small hole (1/8" to 1/4" dia.) in the tailstock end of your workpiece.

Prep the headstock end of your square or irregular workpiece



OR



OPTION 1

Step 3 – Drill a hole (min. 5/8 dia.) in the headstock end of your workpiece. Make the hole deep enough so the jaws do not hit the bottom.

OPTION 2

Step 4 – Attach a round disc (max. 1" dia.) to the end of your stock with glue or a screw.

Round material (up to 1" dia.) does not require headstock prep and can be held directly inside the three jaw chuck.

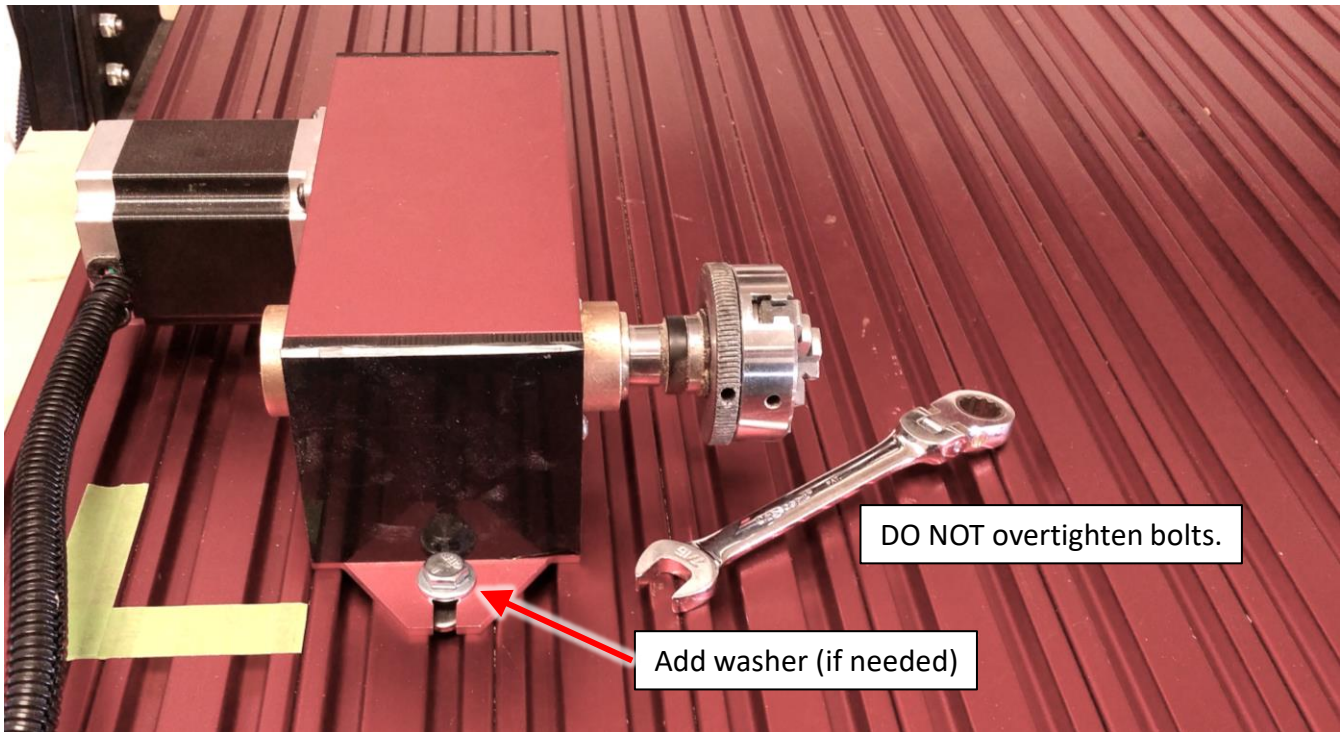

Step 4 – Secure the headstock to the table using the provided bolts and T-slot nuts. (Depending on your machine, you may need to add washers to keep the bolts from hitting the bottom of the T-Slot)

When installing "Along Y Axis" use a framing square to ensure the headstock is square to the table.

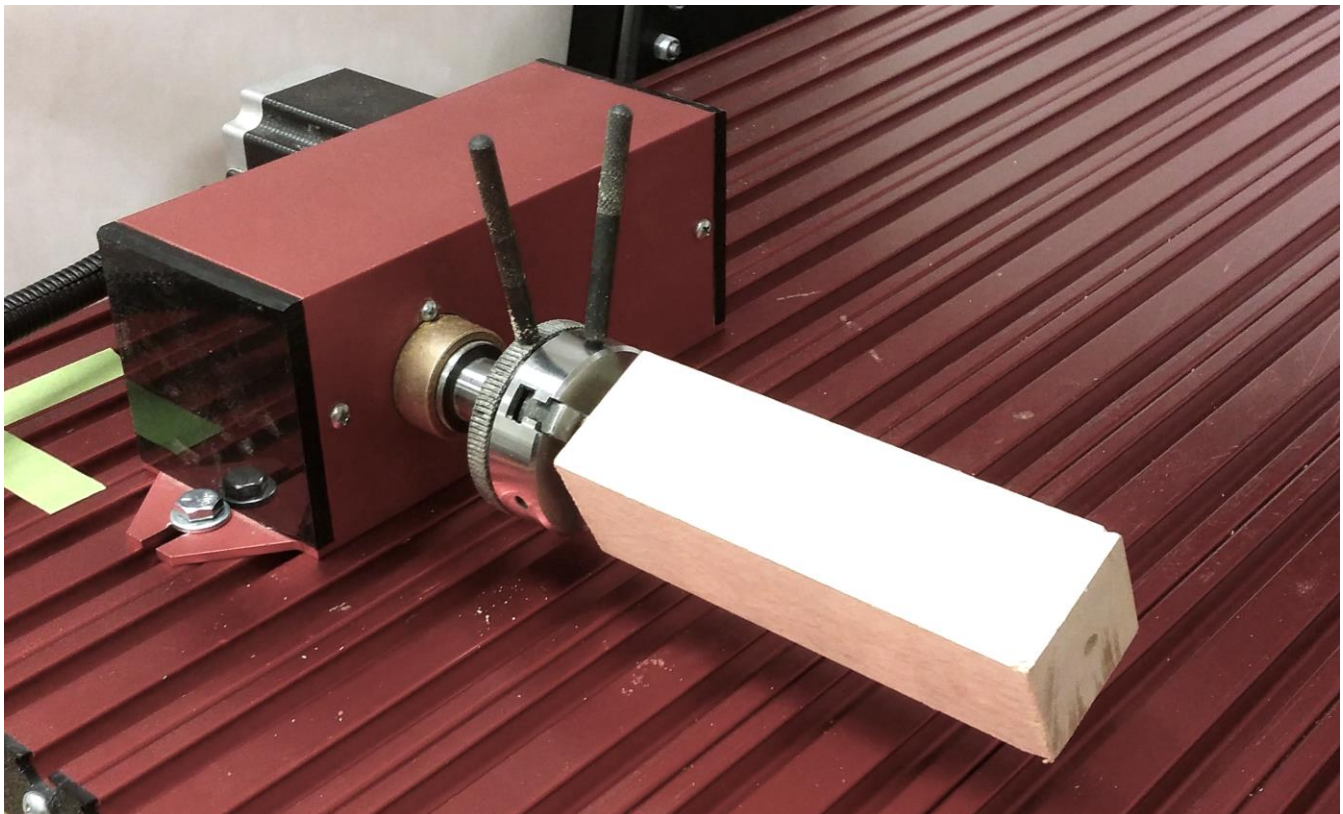

Step 5 – Lightly mount the workpiece in the headstock.

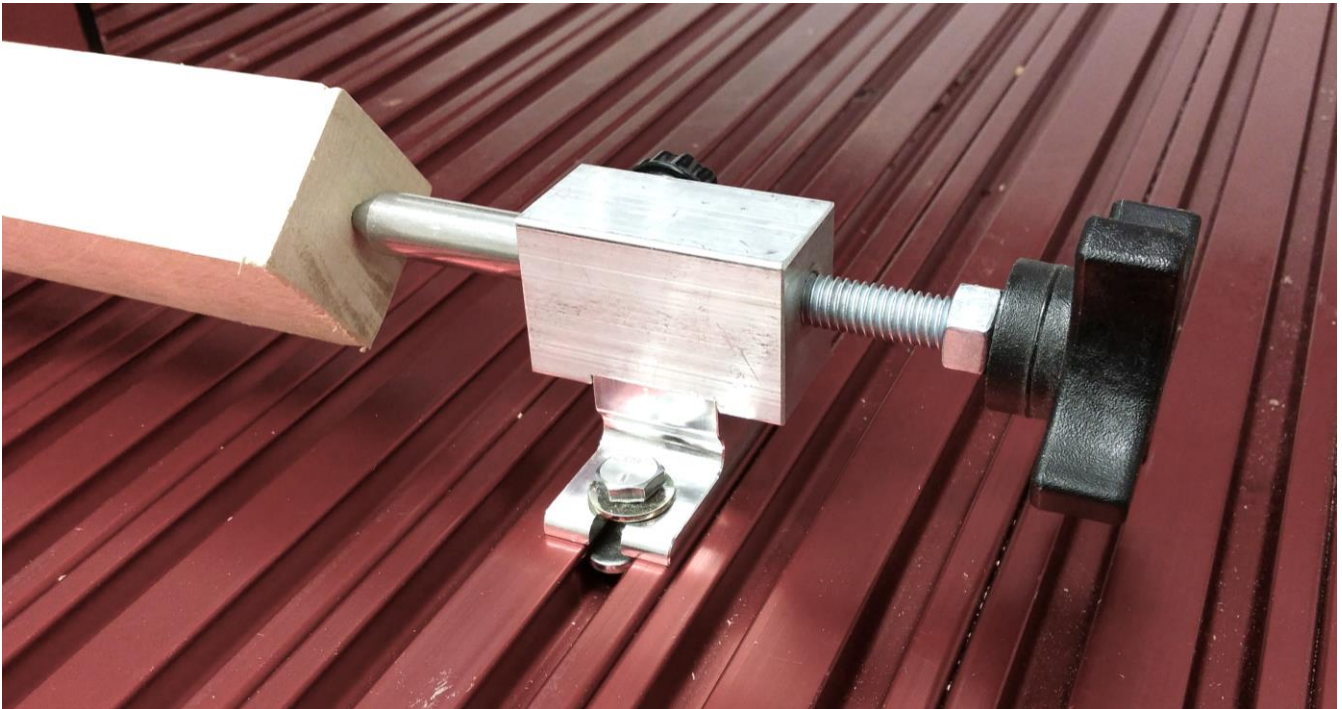

Step 6 – Slide the tailstock up to the small hole in the end of the workpiece. This provides the approximate spacing between the head and tail stocks. Make sure there is enough travel distance in the tailstock center so it can be tightened against the workpiece after the tailstock is secured to the table.

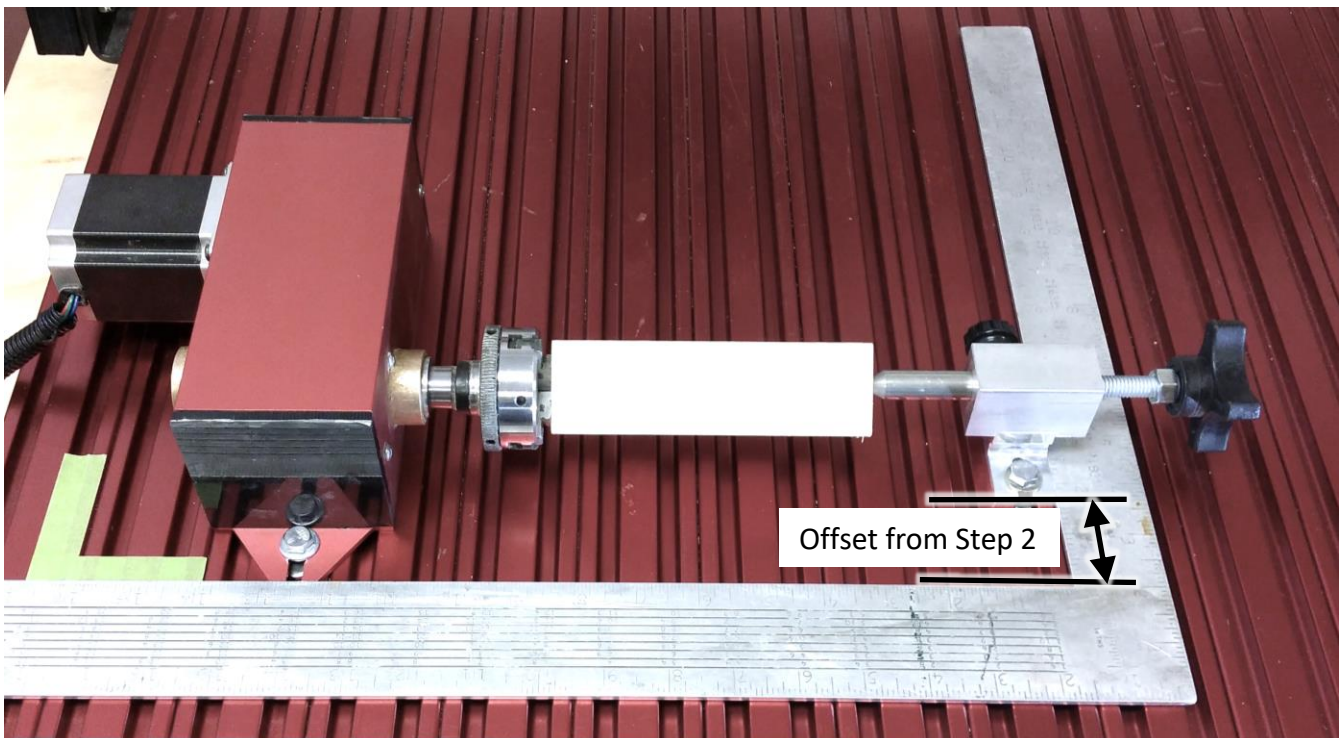

Step 7 – Square the tailstock to the headstock using a framing square and the offset measurement from Step 2. At this time, only finger tighten the bolts in the tailstock base. They will be fully tightened later.



Step 8 – Put a v-bit in the jaw chuck and collet. Align the tips of the bits vertically.

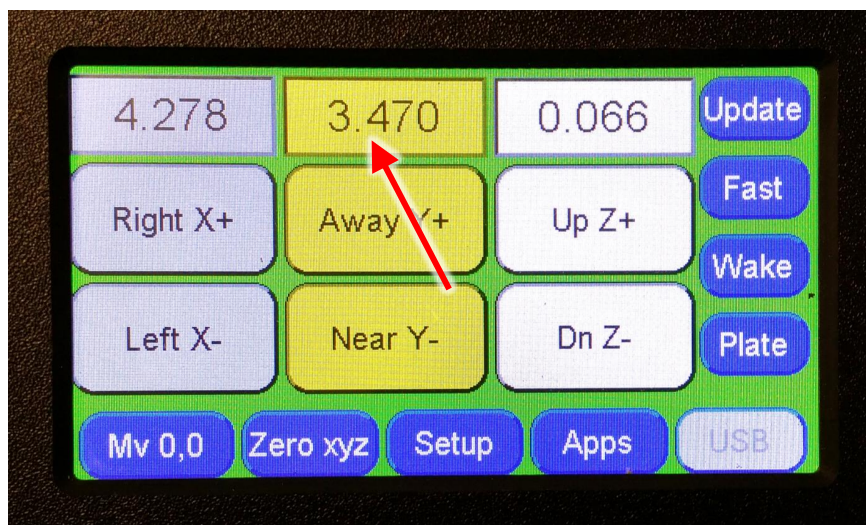

Step 9 – Press on the position field above the Y to open the Y axis keypad.

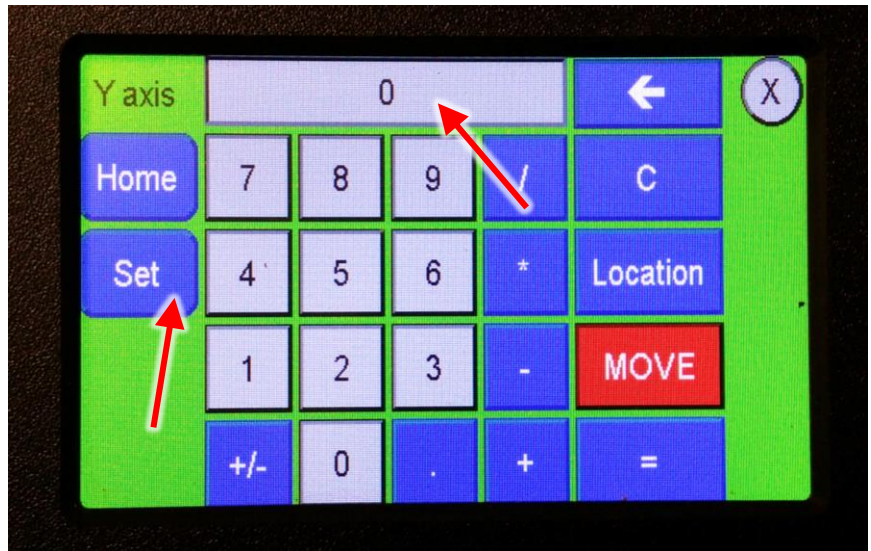

Step 10 – Enter **0**, and then **Set** to accept change.

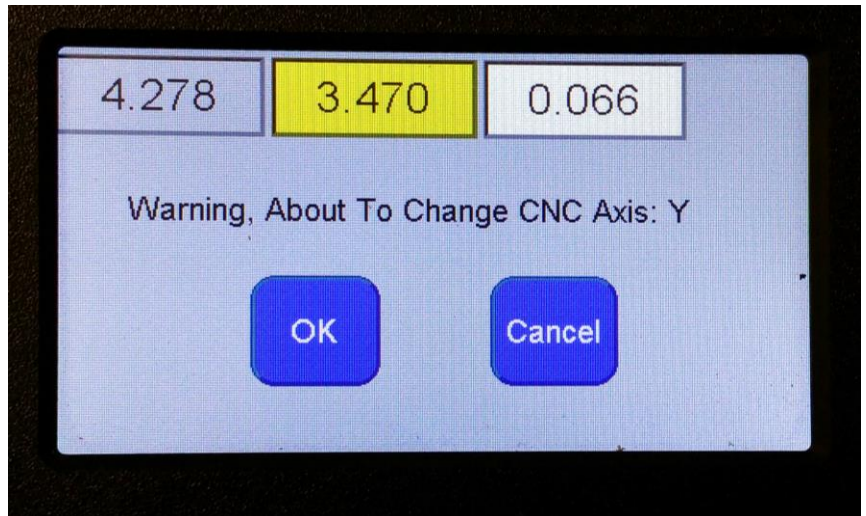

Step 11 – Press **OK** to finalize change.

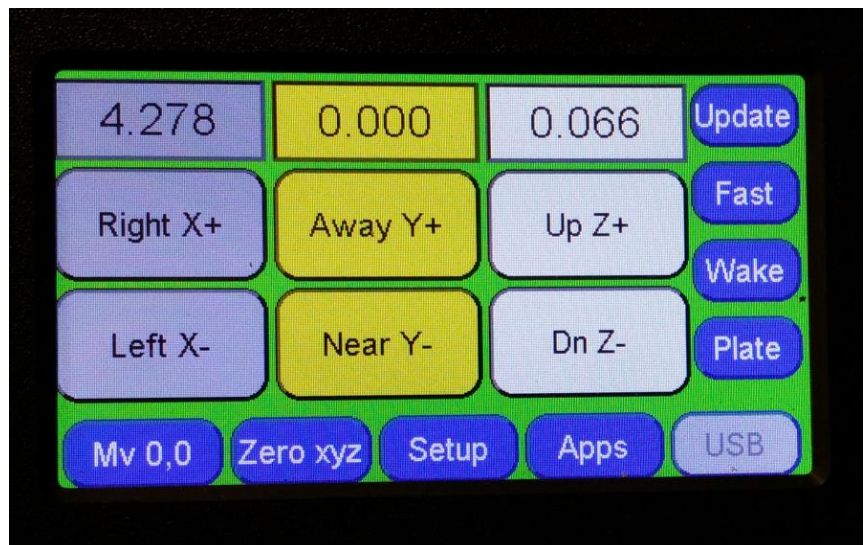

Step 12 – The Y axis is now zeroed to the center of the headstock.



Step 13 – Jog the v-bit over the tailstock center. Adjust tailstock so it aligns (vertically) with the tip of the router bit. Then tighten the tailstock mounting bolts.



Step 14 – The headstock and tailstock are now aligned. Reinstall material, tighten the jaws and and set tailstock center so it's snug in the drilled hole. You are almost ready to start machining. See page 42 for step-by-step instruction on creating and running a 4th axis toolpath file.

Basic Rotary 4th Axis workflow summary

Not all of the following steps are required for every file or setup and some may need to be modified depending on the project.

1. Create your design and toolpaths using Vectric VCarve or Aspire software.
2. Save toolpath g-code .tap file to a USB thumb drive.
3. Use appropriate safety equipment and protection
4. Mount the Rotary 4th Axis to your CNC table and square it to the gantry.
5. Install your material between the head and tail stocks.
6. Turn the power on to the control box.
7. Install the required bit.
8. Zero the bit to the XY location used in the VCarve or Aspire design file.
9. Zero the bit to the Z location used in the VCarve or Aspire design file.
10. Zero the A (wrapped) axis as needed for square stock.
11. Insert thumb drive containing your .tap file into the Pendant.
12. Press "Run-G-Code" button on the Home screen
13. Select .tap file for your project
14. Confirm file settings
15. Run file and monitor it's progress.
- 16. DO NOT LEAVE MACHINE UNATTENDED until file is complete.**

Loading and running the job in the 4th axis mode is similar to the 3 axis mode. Once you've selected the file and it is loaded, hit 'Run'. Press 'OK' if you are ready to run the tap file.

In some configurations, you may need to start the router/spindle and let it get up to speed before clicking on 'OK' to start the job.

The Run controls – Run File, Continue, Pause, E-Stop – all perform in the same manner as when running a 3-axis job.

Rotary 4th Axis Workflow (Basic Practice Project)



The following instructions walk through the steps of creating a simple fluted cylinder. This exercise assumes you are familiar with how to navigate and create basic designs in VCarve. If you are not familiar with VCarve, we suggest you visit www.vectric.com and familiarize yourself with VCarve before proceeding with this rotary project.

- **The machine setup and machining steps are the same for both the Standard and the Mini 4th Axis.**
- **However some "design" steps are different between VCarve Desktop and VCarve Pro.**

**If your using VCarve Desktop
proceed to Page 43**



**If your using VCarve Pro
proceed to Page 54**





Design phase – Using VCarve Desktop

The following instructions show the basic steps of creating simple fluted cylinder using **VCarve Desktop**. These instructions may appear complicated, but once you go through the process a couple times, you will find that the workflow for rotary is very similar to the workflow for regular CNC projects. If you not used VCarve Desktop, we suggest you visit www.vetric.com and familiarize yourself with VCarve Desktop before proceeding with this rotary project.



For this project you'll need a 1.5" x 1.5" x 10" piece of material for the workpiece.

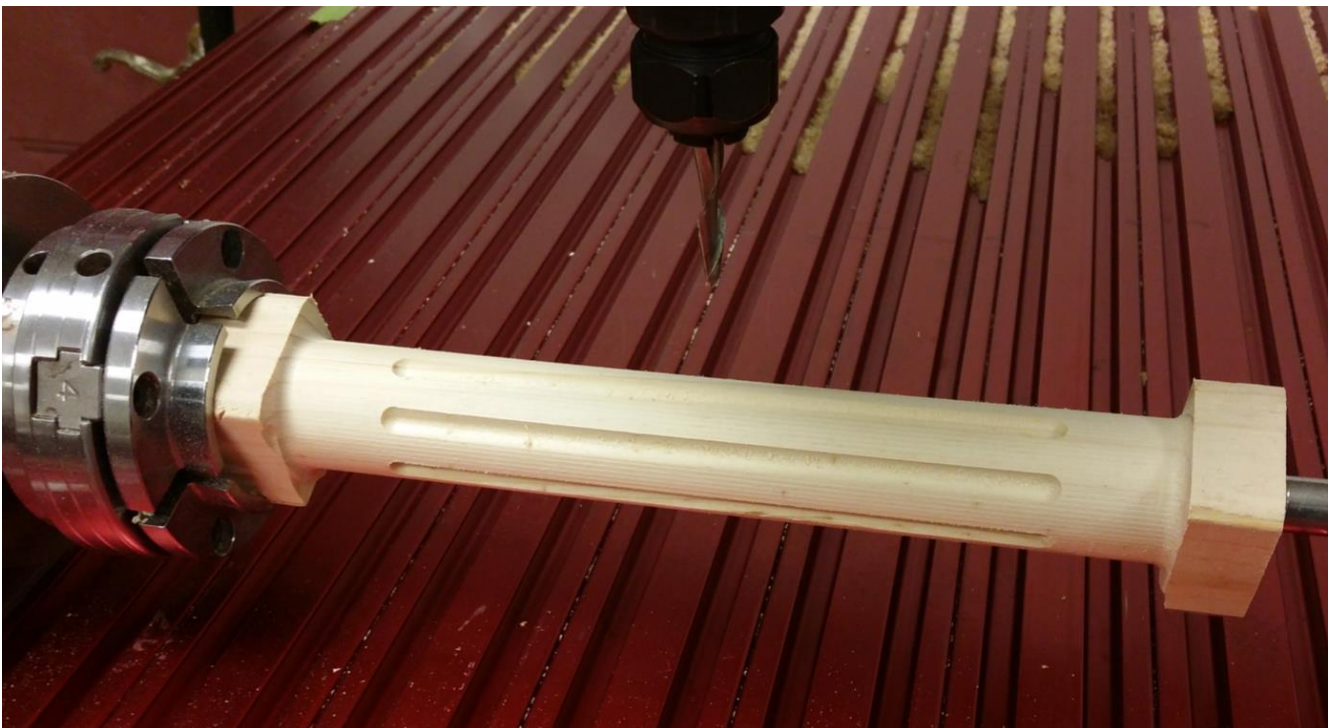

Finished project

Design phase – Using VCarve Desktop

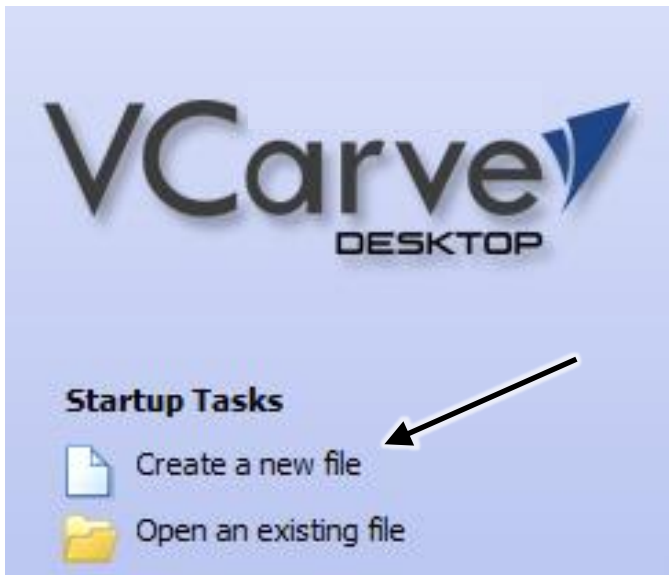

Step 1 – Create a new project

Step 2 – Match the settings in this **Job Setup** window.

SPECIAL NOTE about the setting the Job Size Diameter.

If you're starting with round stock set the Diameter to the diameter of your round stock. BUT if you're starting with square stock (as in this project) set the diameter to the diagonal dimensions of your stock. Rounding off the number to the nearest 1/8" is OK. For this project that equals 2.125". The final project diameter for this project will be 1.25"

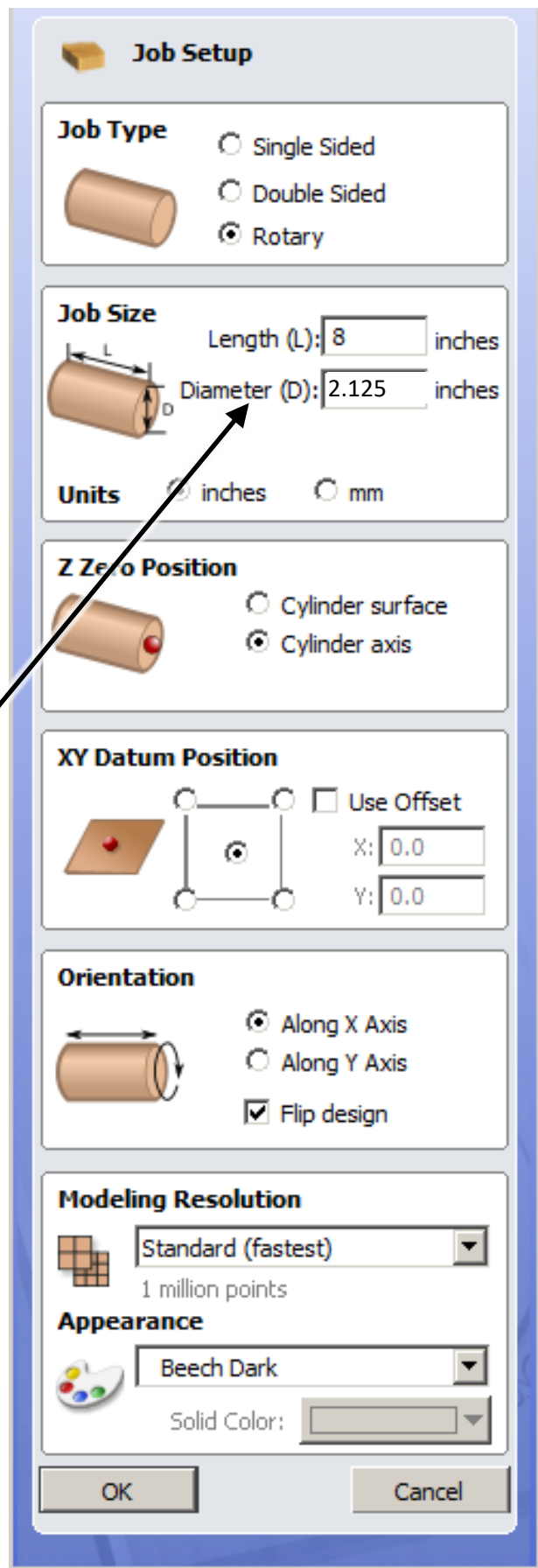
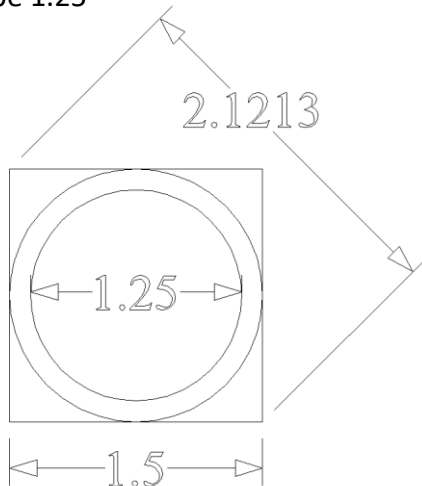



Design phase – Using VCarve Desktop

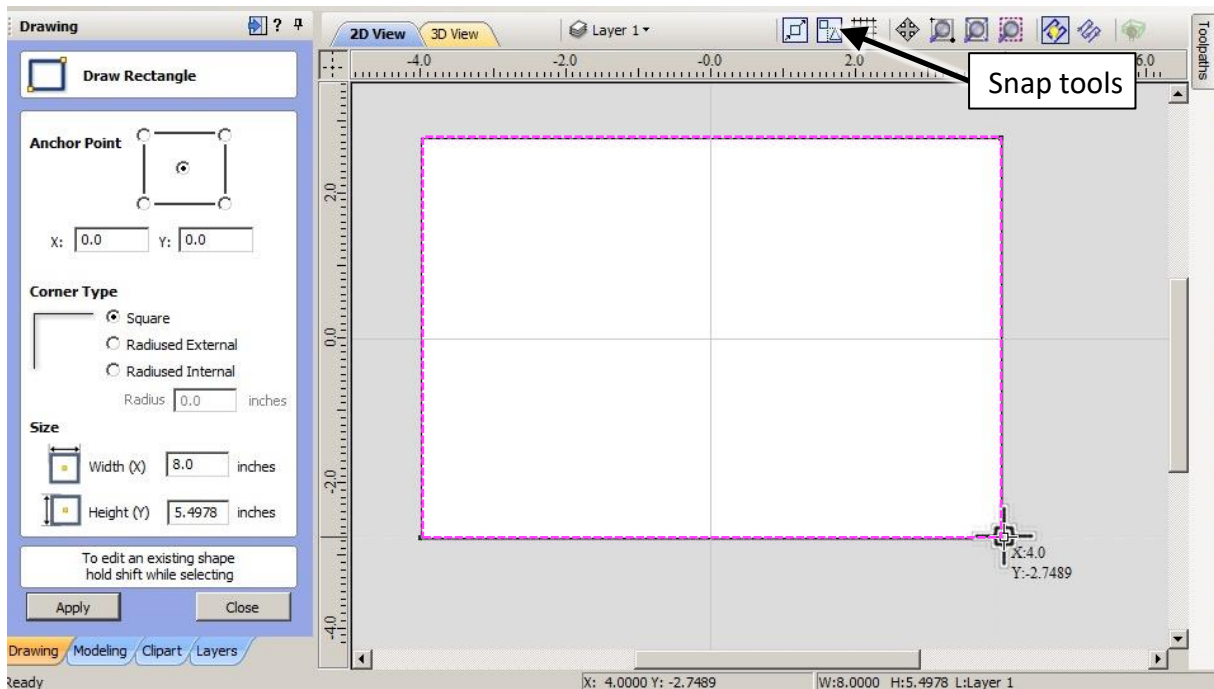

Step 3 – Draw a rectangle around the perimeter of the material. You want this rectangle to be the same size as you’re the material. **TIP:** Using the snap tools to makes this easy. This rectangle will be used to create a "rounding" and "smoothing" toolpath that machines the square stock down to a round cylinder.



Step 4 – Next we will create a toolpath to round the square stock. Open the **Pocket toolpath tool**.



Design phase – Using VCarve Desktop

Step 5 – Click **Select** to open the **Tool Database**. Select a .25 endmill for this "rounding" toolpath step. The **Pass Depth**, **Stepover** and **Feed Rate** will depend on the type of wood you're cutting. Harder materials require shallower cuts. Run some test to determine the best settings for your situation. Once your bit is setup click **Apply** and **Select**.

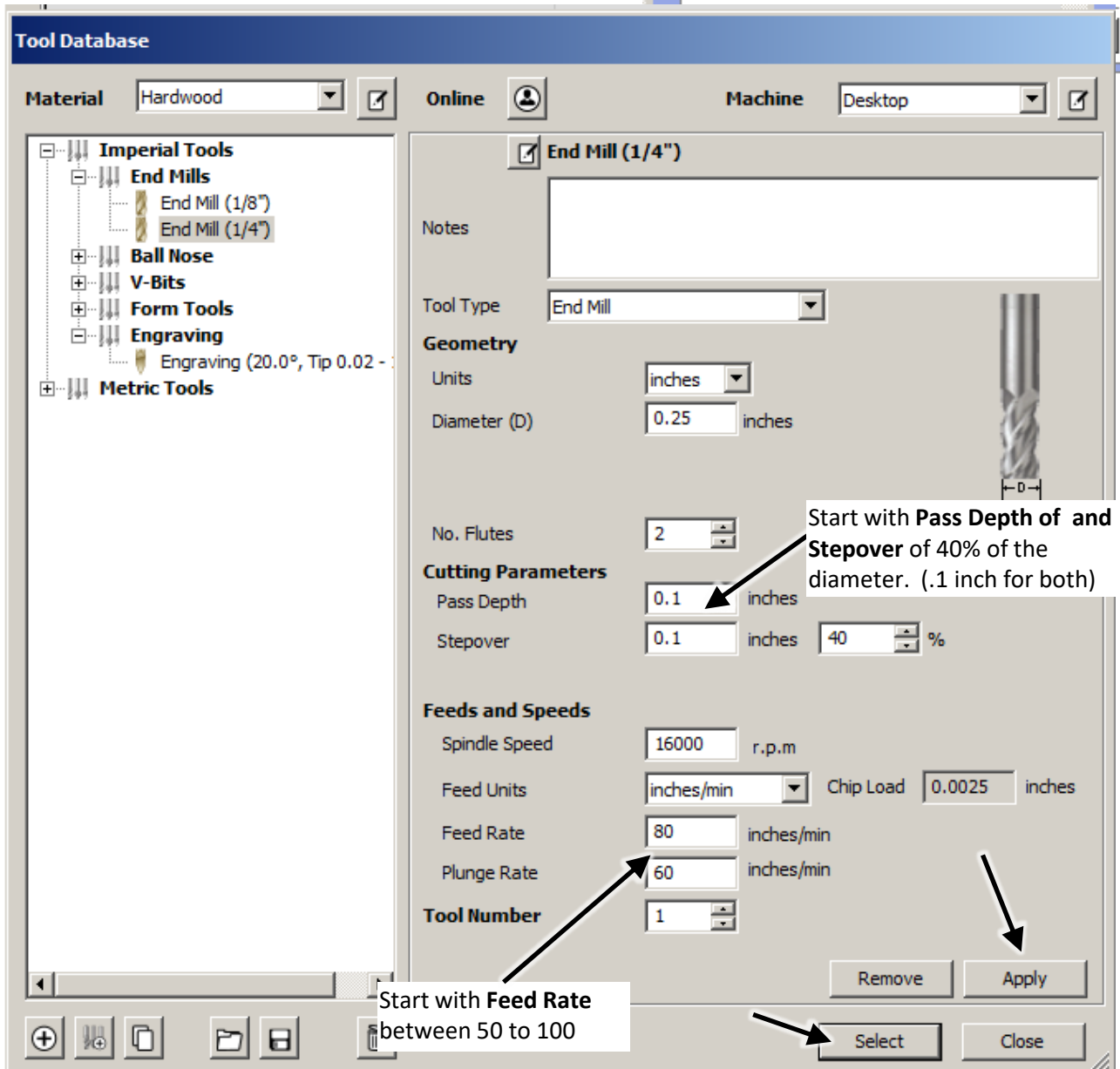
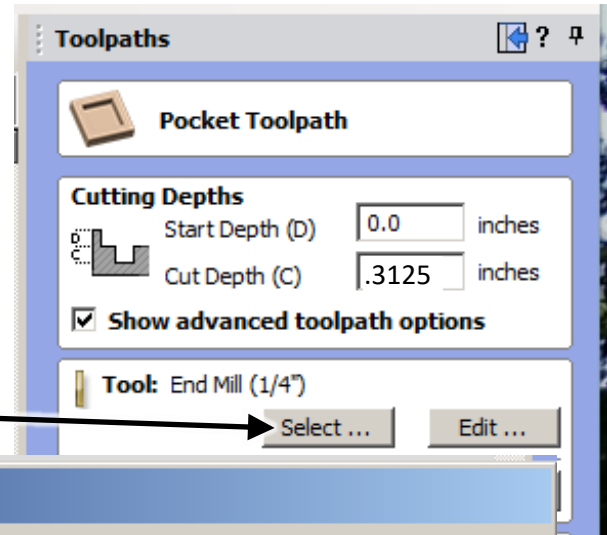

Design phase – Using VCarve Desktop

Step 6 – Set the **Cut Depth** to .3125 (3/16) inches, This will knock off the corners and leave a 1.5 inch in diameter cylinder. It will have some rough texture on the outside since this is only the roughing/rounding pass.

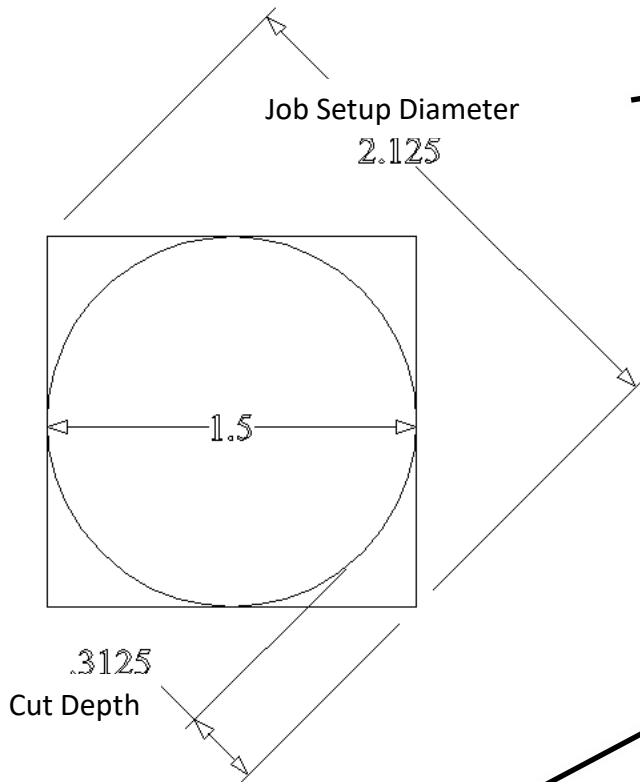

The screenshot shows the 'Toolpaths' dialog box for a 'Pocket Toolpath'. The 'Cutting Depths' section has 'Start Depth (D)' set to 0.0 inches and 'Cut Depth (C)' set to .3125 inches. The 'Tool' is set to 'End Mill (1/4")'. There are 3 passes. The 'Clear Pocket ...' section has 'Raster' selected, with 'Climb' cut direction, a Raster Angle of 0.0 degrees, and a Profile Pass of 'Last'. The 'Pocket Allowance' is set to -0.1 inches. The 'Ramp Plunge Moves' checkbox is checked with a distance of 1.0 inches. The 'Name' field contains 'Rounding toolpath'. The 'Calculate' button is highlighted.

Step 7 – Set to **Raster**

Step 8 – If needed, add some negative Pocket Allowance to ensure that the toolpath machines the entire cylinder. Or stretch the size of the perimeter rectangle

Step 9 – Add a Name

Step 10 – Make sure the Perimeter rectangle is selected, then click **Calculate**



Design phase – Using VCarve Desktop

Step 11 – Open the **Pocket toolpath** tool again. This time we will create a toolpath to smooth the rough cylinder and reduce it to final diameter. Click **Select** to open the **Tool Database**. Select and setup a 1/4 inch dia. ballnose bit.

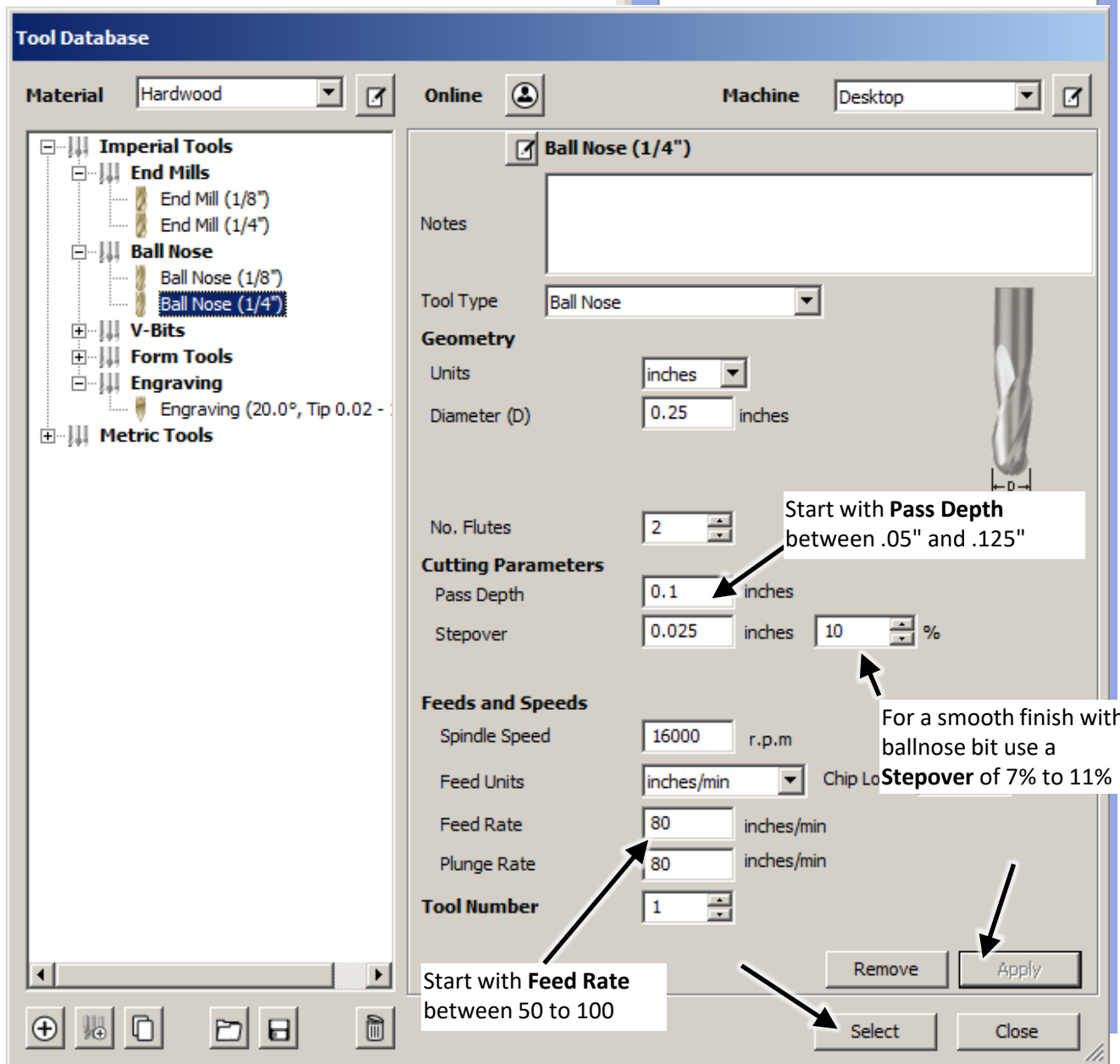
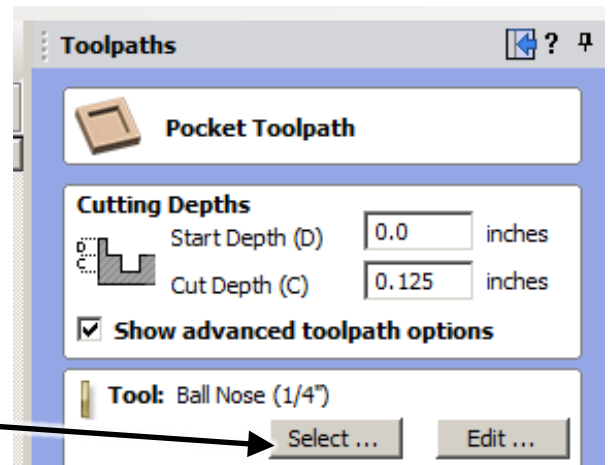

Design phase – Using VCarve Desktop

Step 12 – Set the Start Depth to .3125 (the Cut Depth for the Rounding toolpath) Then set the **Cut Depth** to .125 (1/8) inches, This will smooth the the cylinder to it final diameter of 1.25 inches.

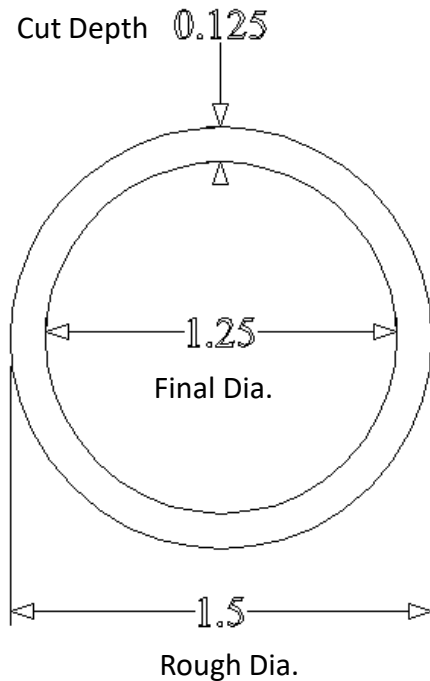

Step 13 – Set to Raster

Step 14 – If needed, add some negative Pocket Allowance to ensure that the toolpath machines the entire cylinder. Or stretch the size of the perimeter rectangle

Step 15 – Add a Name

Step 16 – Make sure the Perimeter rectangle is selected, then click **Calculate**

The screenshot shows the 'Toolpaths' panel in VCarve Desktop. It is configured for a 'Pocket Toolpath' with the following settings:

- Cutting Depths:** Start Depth (D) is 0.3125 inches, Cut Depth (C) is 0.125 inches. The 'Show advanced toolpath options' checkbox is checked.
- Tool:** Ball Nose (1/4").
- Passes:** 2.
- Use Larger Area Clearance Tool:** Not checked. The status is 'Not using area clear tool'.
- Clear Pocket ...:** The 'Raster' radio button is selected. The 'Cut Direction' is set to 'Climb'. The 'Raster Angle' is 0.0 degrees and the 'Profile Pass' is set to 'Last'.
- Pocket Allowance:** -0.1 inches.
- Ramp Plunge Moves:** Checked, with a distance of 1.0 inches.
- Use Vector Selection Order:** Not checked.
- Safe Z:** 0.2 inches.
- Home Position:** X:0.00 Y:0.00 Z:0.21.
- Project toolpath onto 3D model:** Not checked.
- Vector Selection:** Manual.
- Name:** Smoothing.



Design phase – Using VCarve Desktop

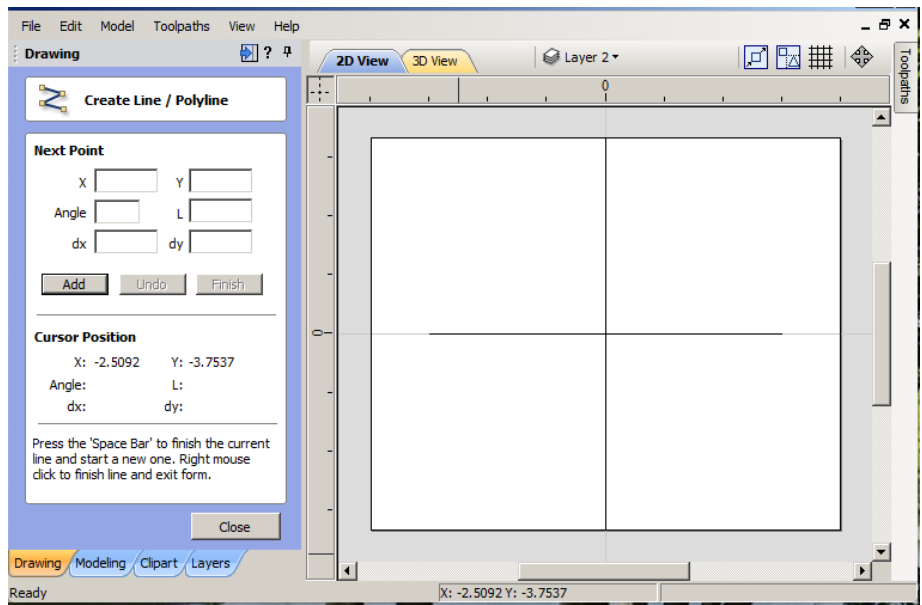

Step 17 – Next we will draw the lines for the flutes. Start by drawing a vertical line that touches the top and bottom edge of the material. Next draw a 6 inch horizontal line in the center. This 6 inch line represents the length of the flutes.

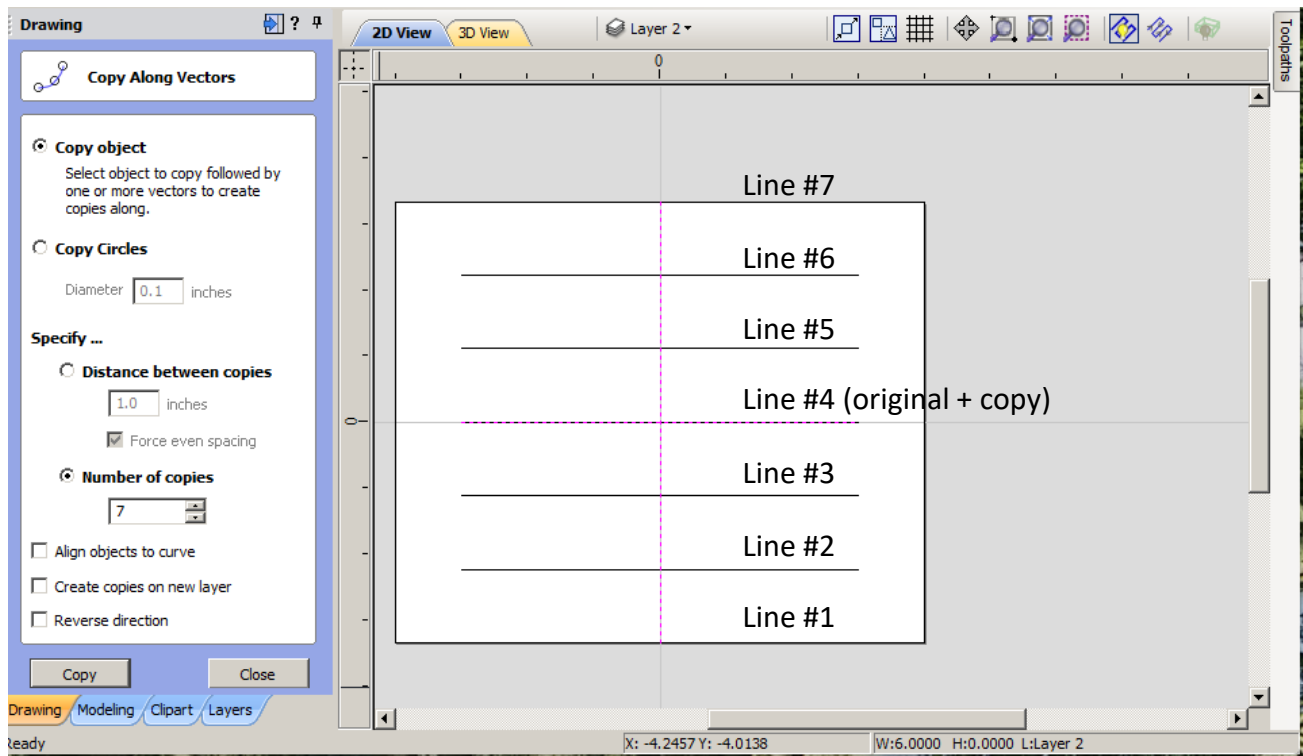

Step 18a – Use the Copy Along Vectors tool to create 7 horizontal lines.

Step 18b – Delete line #7 at the top edge.

Step 18C – Delete one of the duplicate #4 lines and the vertical line

The remaining 6 lines will be used for the flutes.



Design phase – Using VCarve Desktop

Step 19 – Open the fluting toolpath.

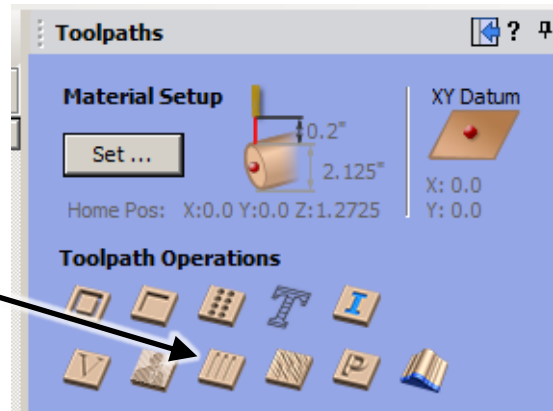

Step 20 – Set the **Start Depth** to half of the difference between the **Job Setup Diameter** and the smooth/ final project cylinder diameter.

For this project that's $2.125 - 1.25 = .875 / 2 = .4375$.

Calculating the "Start Depth" this way is necessary because VCarve calculates the toolpath from the surface of the **Job Setup Diameter**.

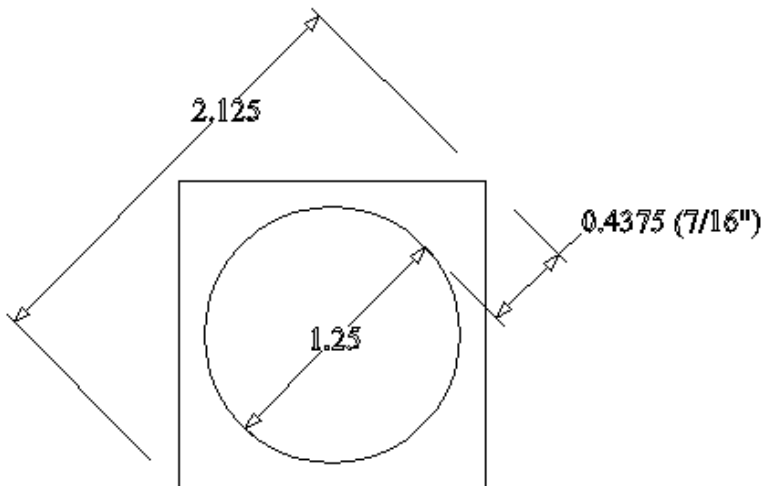

Step 21 – Set the remaining parameters as shown or as you prefer. Make sure the fluting lines are selected and then click **Calculate**.

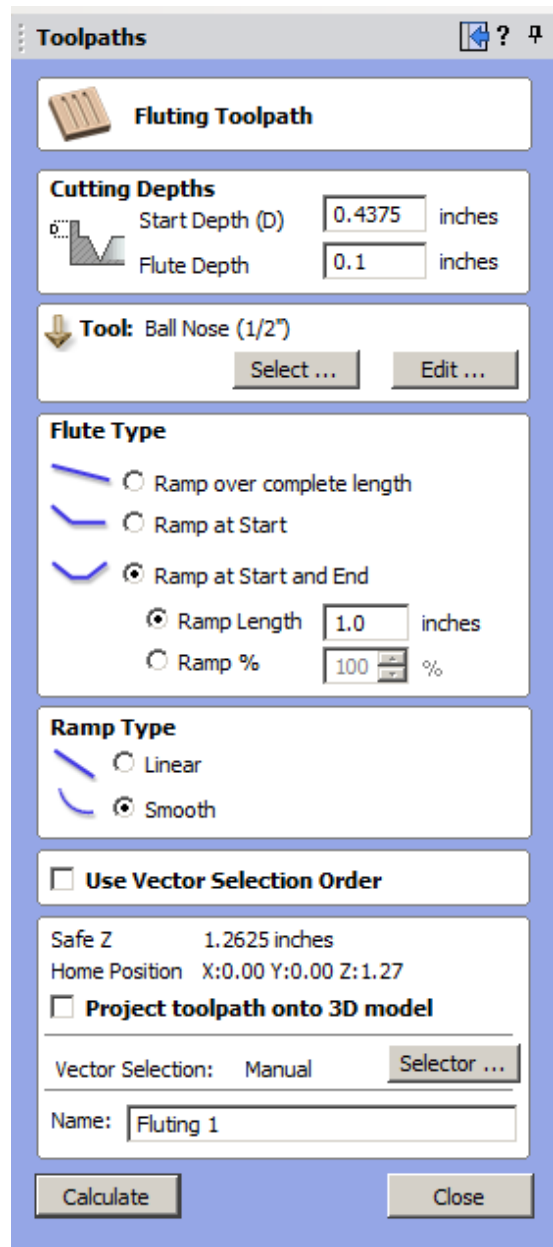



Design phase – Using VCarve Desktop

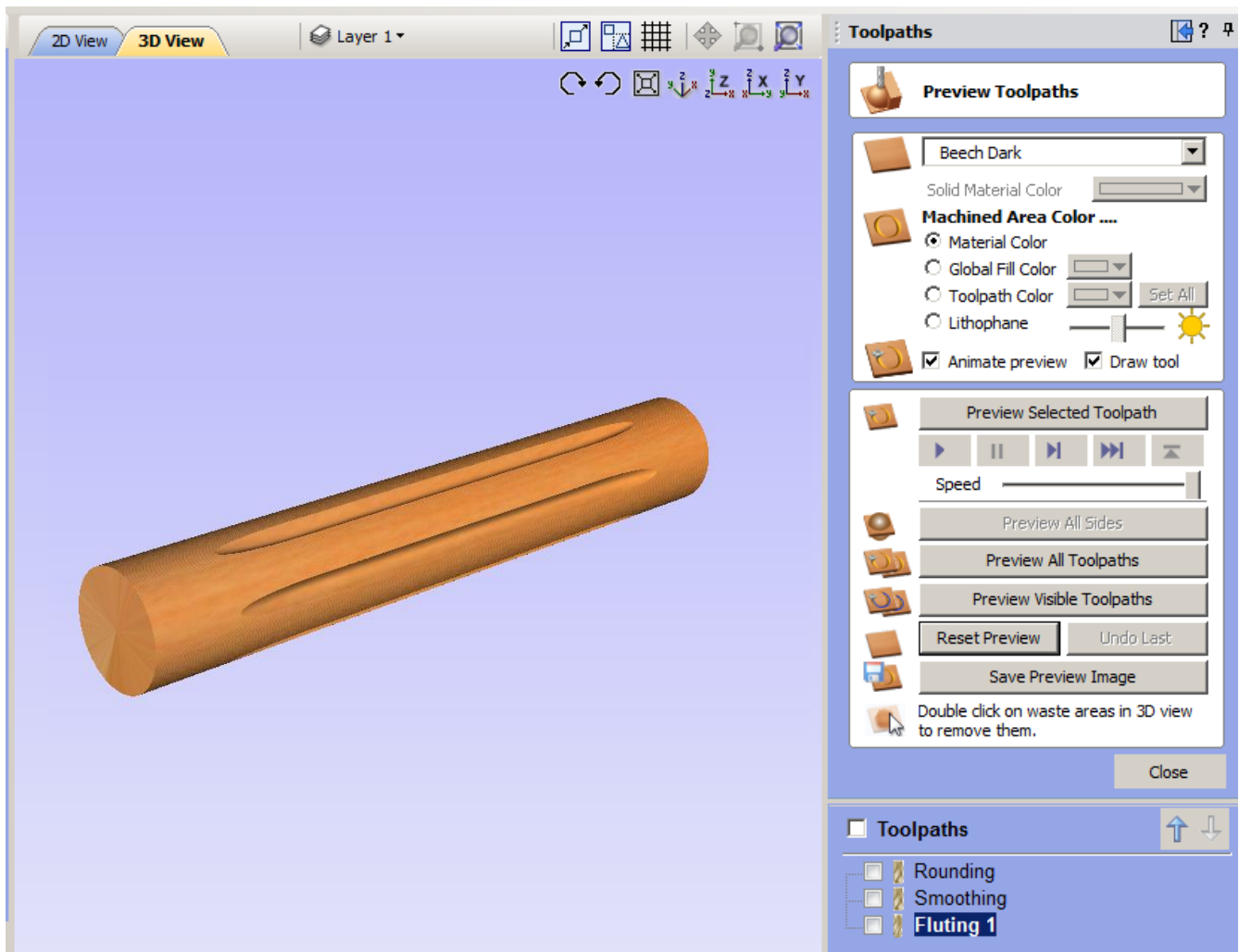

Step 22 – Preview All Toolpaths. It should look like the image above. If your preview doesn't match, review your steps and make the necessary corrections.



Design phase – Using VCarve Desktop

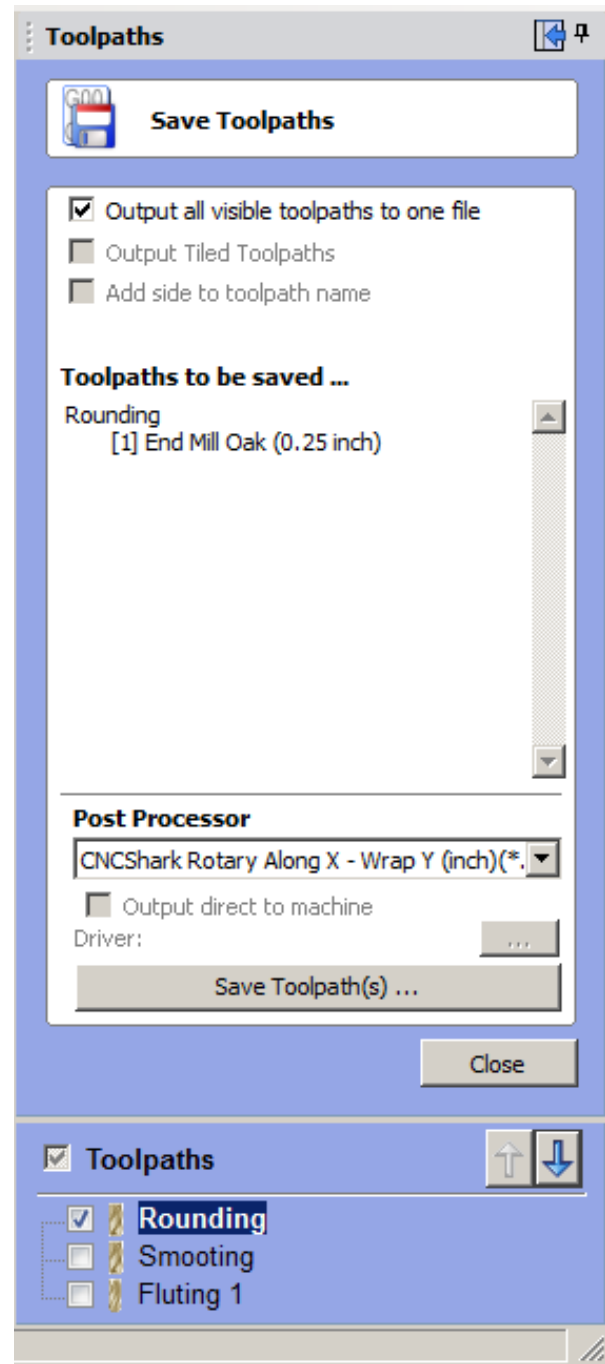

Step 23 –Use the **Along X – Wrap Y** post processor, and save the toolpaths to a thumb drive.

(NOTE: the name of most current post processor may vary from the one shown here.)

PROCEED TO PAGE 62
FOR STEPS ON HOW TO SETUP OF YOUR CNC
MACHINE TO RUN THIS ROTARY FILE.



Design phase – Using VCarve Pro

The following instructions show the basic steps of creating simple fluted cylinder using **VCarve Pro**. These instructions may appear complicated, but once you go through the process a couple times, you will find that the workflow for rotary is very similar to the workflow for regular CNC projects. If you not used VCarve Pro, we suggest you visit www.vectric.com and familiarize yourself with VCarve Pro before proceeding with this rotary project.



For this project you'll need a 1.5" x 1.5" x 10" piece of material for the workpiece.

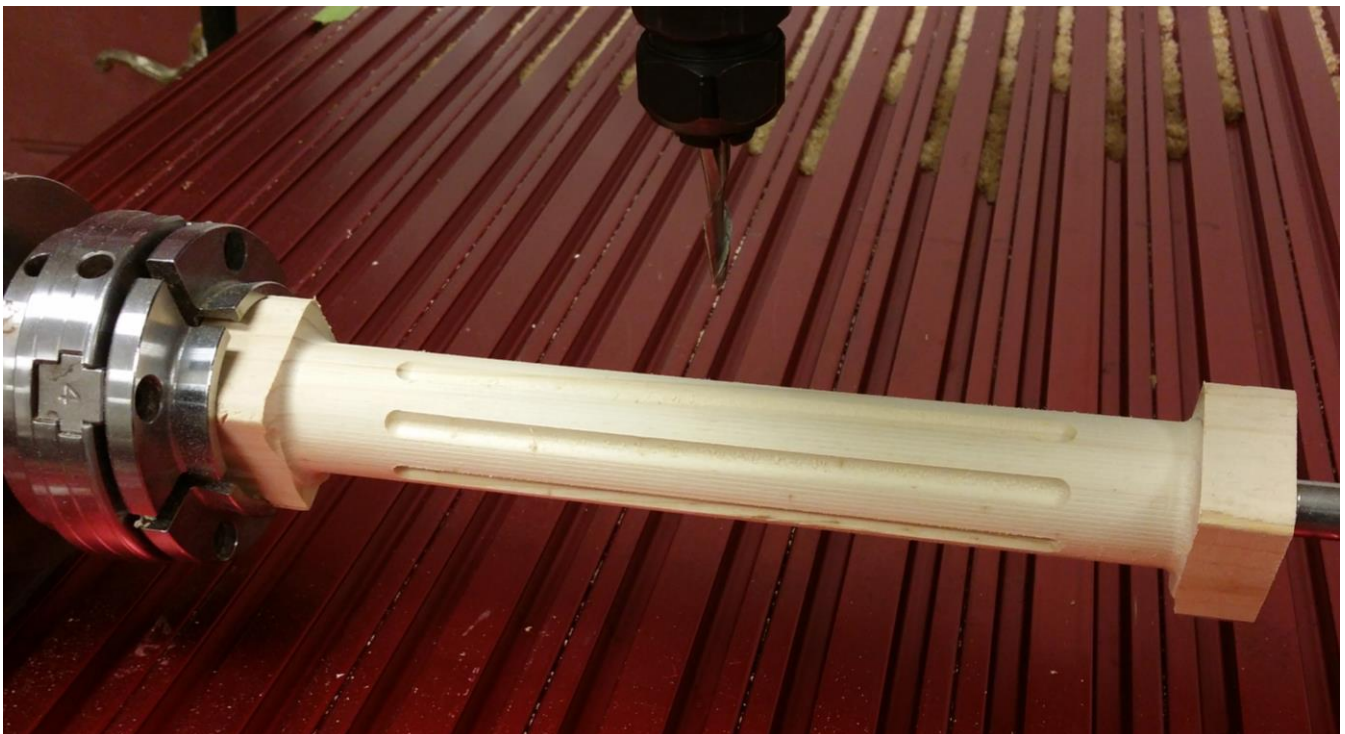

Finished project

Design phase – Using VCarve Pro

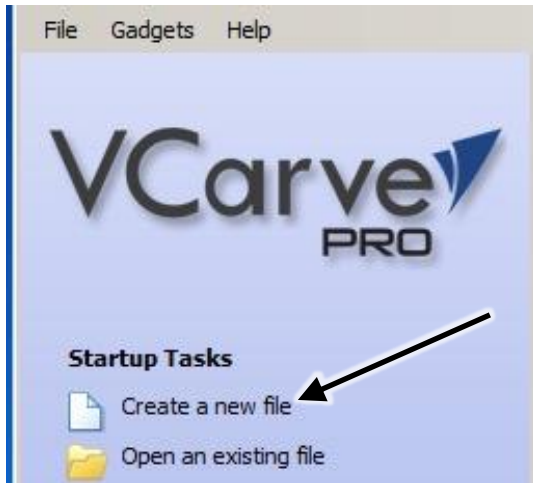

Step 1 – Create a new file

Step 2 – Match the settings in this Job Setup window.

Job Setup

Job Type

- Single Sided
- Double Sided
- Rotary

Job Size

Length (L): inches

Diameter (D): inches

Units

- inches
- mm

Z Zero Position

- Cylinder surface
- Cylinder axis

XY Datum Position

Use Offset

X:

Y:

Orientation

- Along X Axis
- Along Y Axis
- Flip design

Modeling Resolution

1 million points

Appearance

Solid Color:

OK Cancel



Design phase – Using VCarve Pro

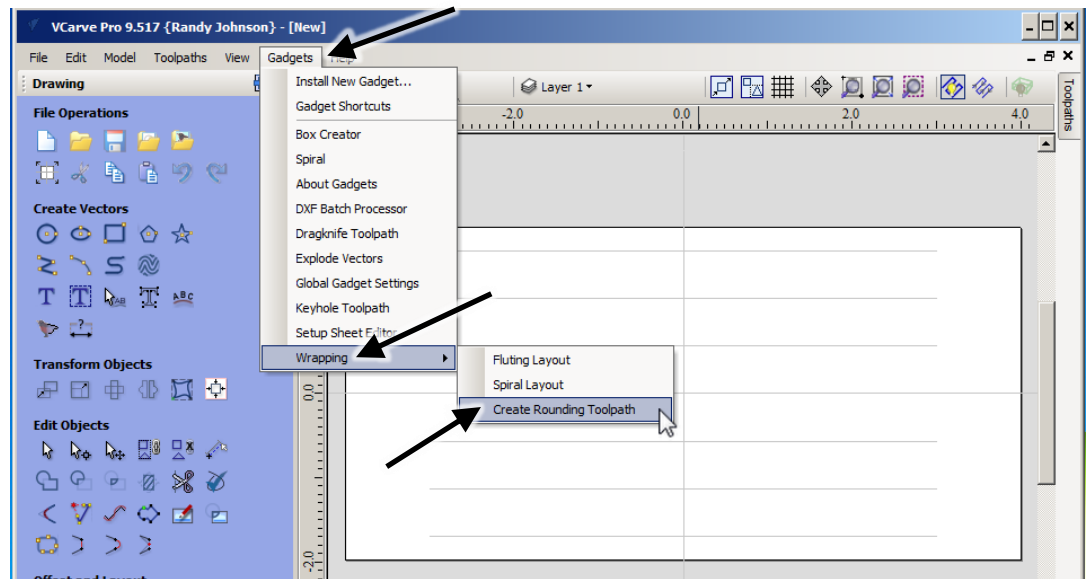

Step 3a – Open Gadgets > Wrapping > Create Rounding toolpath

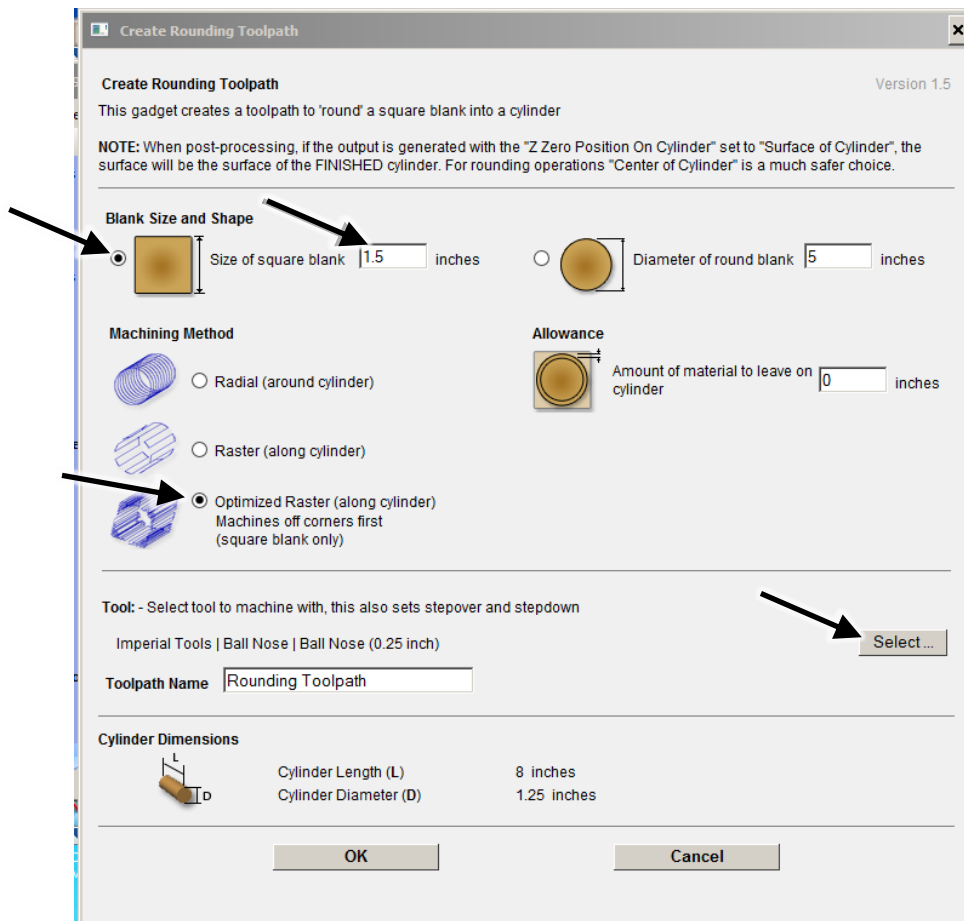

Step 3b – Match the settings in the window above. This step will create a toolpath that will reduce the 1.5" square stock to the final 1.25" cylinder. Open the "Select" button to setup the router bit.



Design phase – Using VCarve Pro

Step 4a – Match these settings in the tool Info window above. Click **Apply** and **OK** to close the window. For this project we're using a .25 ballnose bit for the rounding, which is the same bit that will be used for the fluting – this saves a bit change. **Pass Depth** and **Feed Rate** will depend on the type of material you're cutting. Harder materials may require shallower cuts and/or slower speeds. Run some test to determine the best settings for your situation. Once your bit is setup click **Apply** and **OK**

Step 4b –In the Rounding Toolpath Setup window click **OK** to save the settings and close the window. The **Rounding Toolpath** will now appear in the **Toolpaths** list.



Design phase – Using VCarve Pro

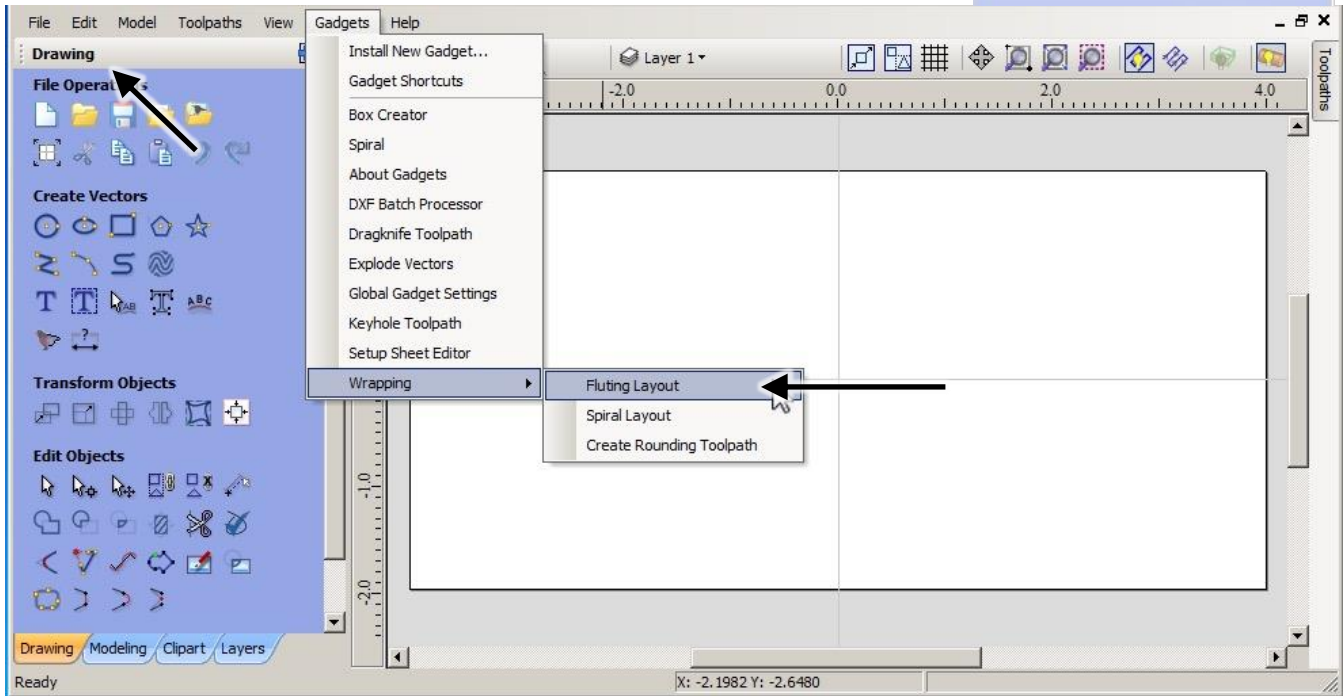

Step 5 – Open Gadgets > Wrapping > Fluting

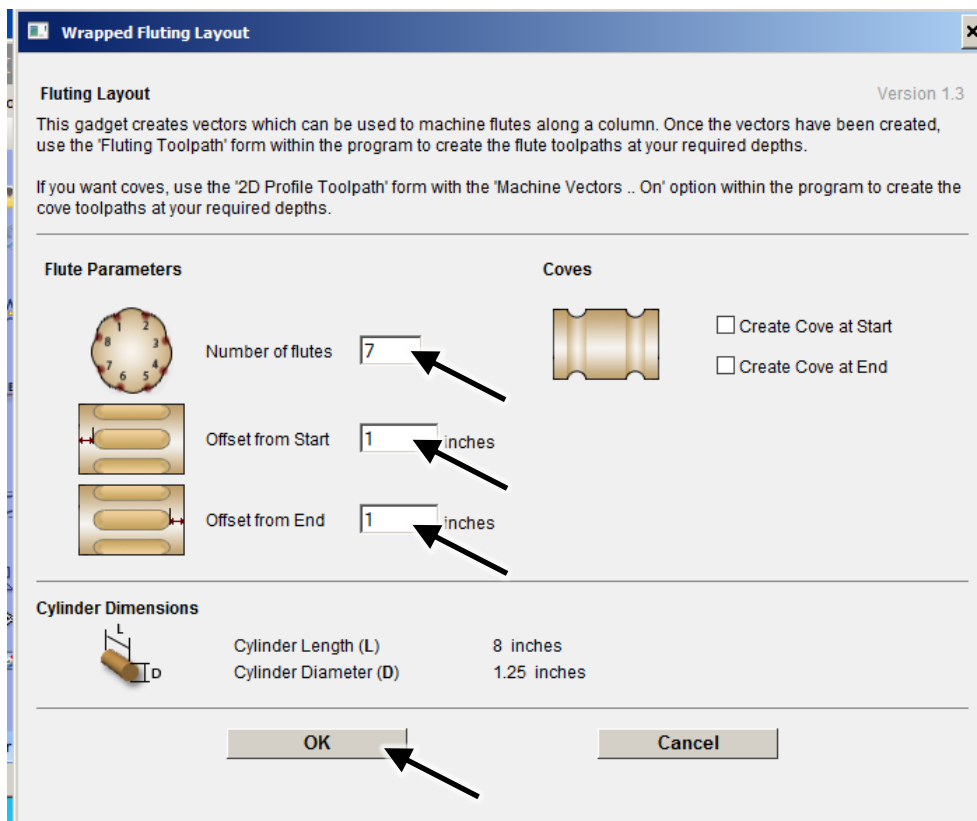

Step 6 – Match the fluting settings in this window. Click **OK to create fluting lines. The fluting lines will now appear in your drawing. See picture in Step 6.**

Design phase – Using VCarve Pro

Step 7 – Open the **Fluting** toolpath

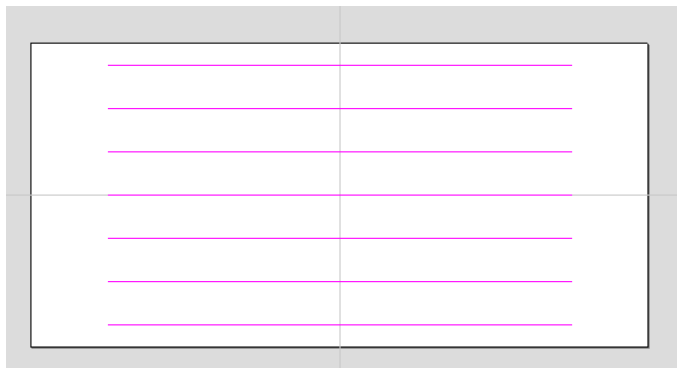
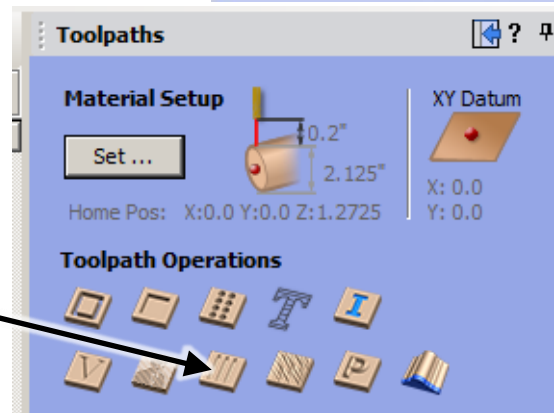

Step 8 – Set the remaining parameters as shown or as you prefer. Make sure the fluting lines are selected and then click **Calculate**.

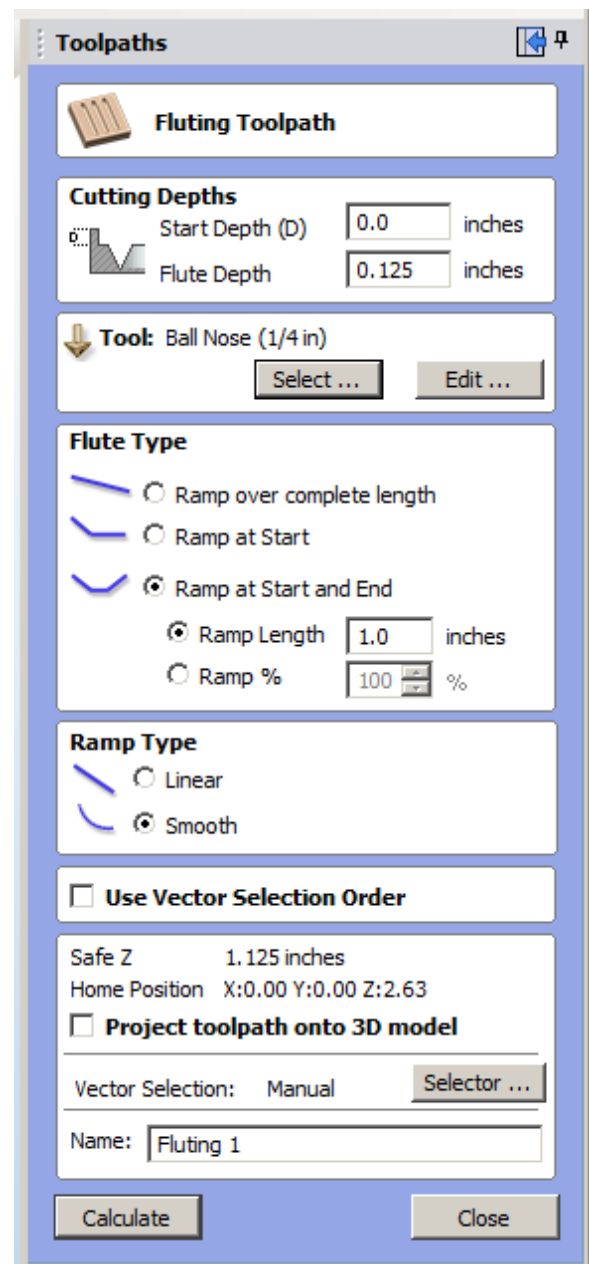



Design phase – Using VCarve Pro

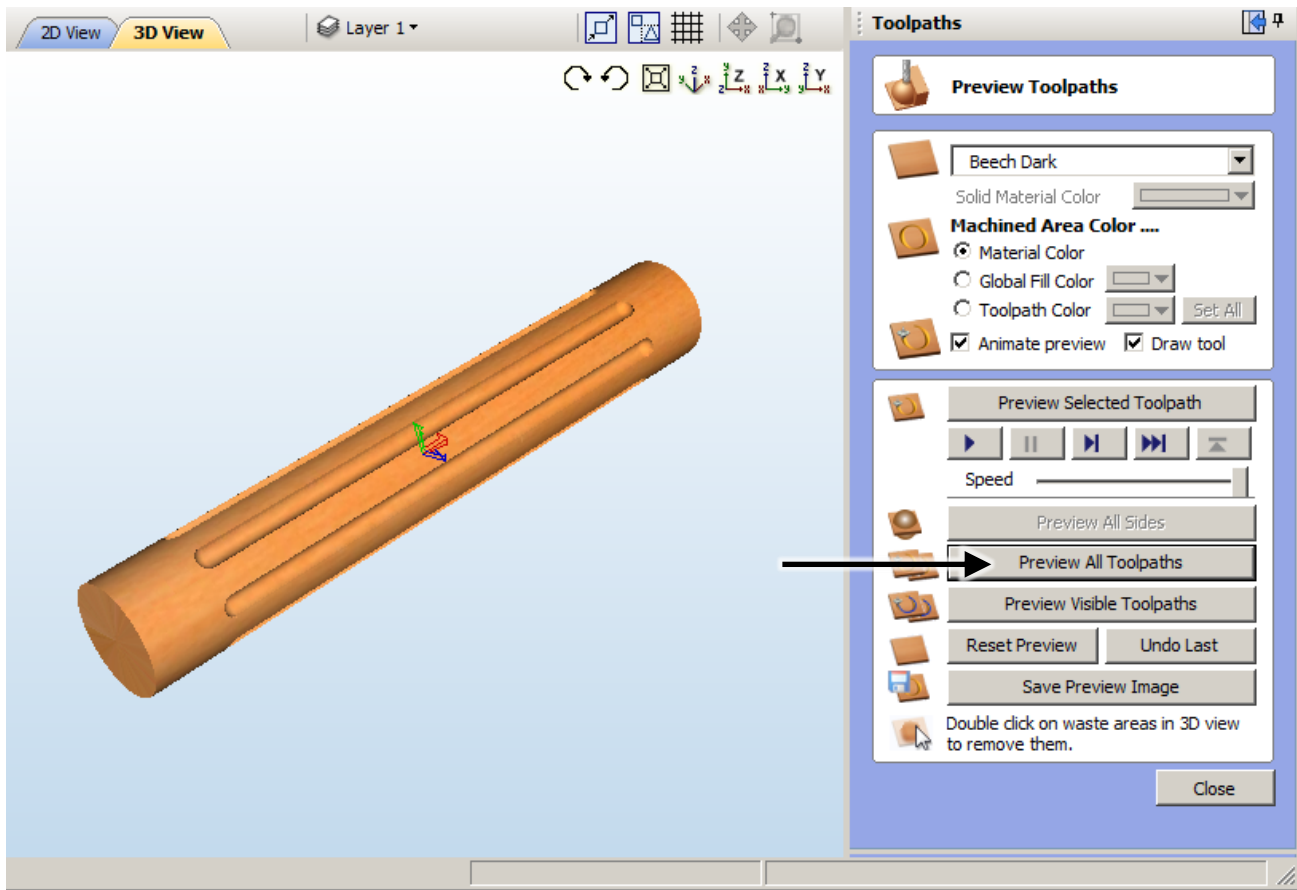

Step 9 – Preview All Toolpaths. It should look like the image above. If your preview doesn't match, review your steps and make the necessary corrections.

Design phase – Using VCarve Pro

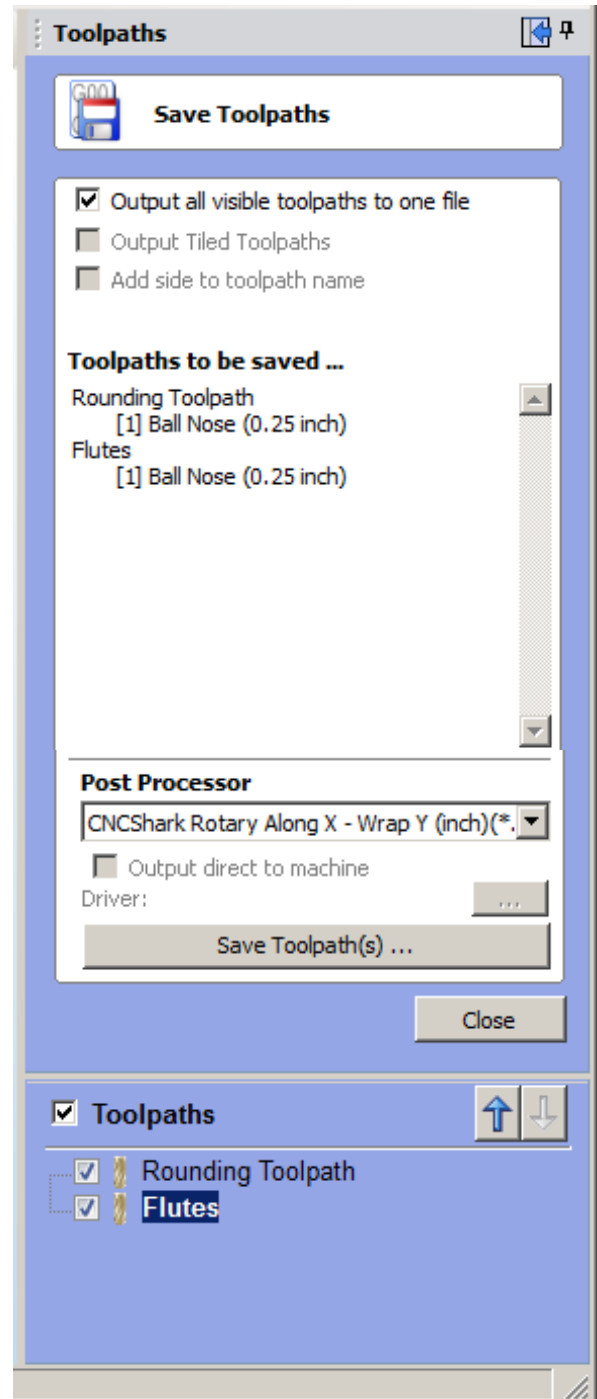

Step 10 – Use the **Along X – Wrap Y** post processor, and save the toolpaths to a thumb drive. Since we are using the same bit for both cuts we can save them as one file.

(NOTE: the name of most current post processor may vary from the one shown here.)

PROCEED TO PAGE 62 FOR STEPS ON HOW TO SETUP OF YOUR CNC MACHINE TO RUN THIS ROTARY FILE.

4th Axis Zeroing process



Step 1 – Install the workpiece (for this exercise use a piece that’s 1.5" x 1.5" x 10")
And zero the Y per the instructions on pages 21-27 for the Standard or pages 34-40 for the Mini.

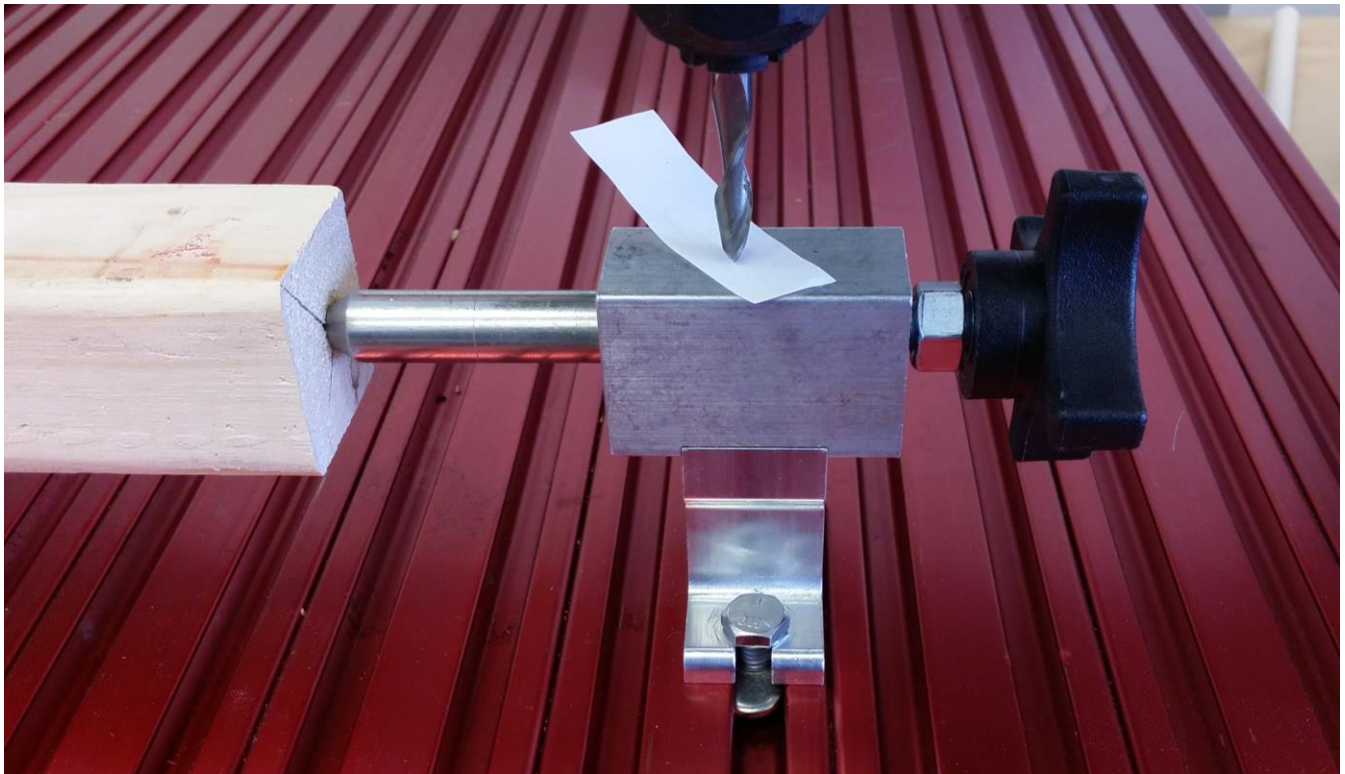

Step 2– Install the required router bit (.25 dia. ballnose for this project) and jog it down to a piece of paper on top of the tailstock.

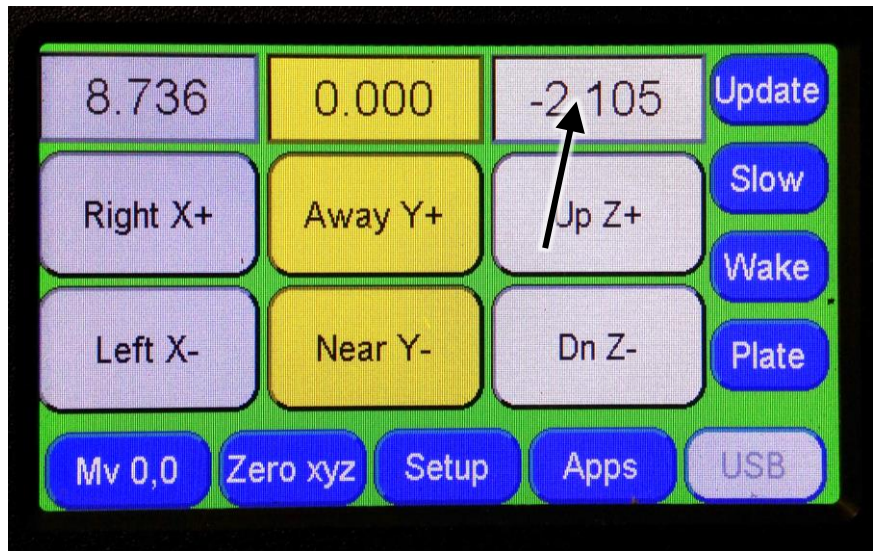

Step 3 – Press the Z position field to open the Z keypad

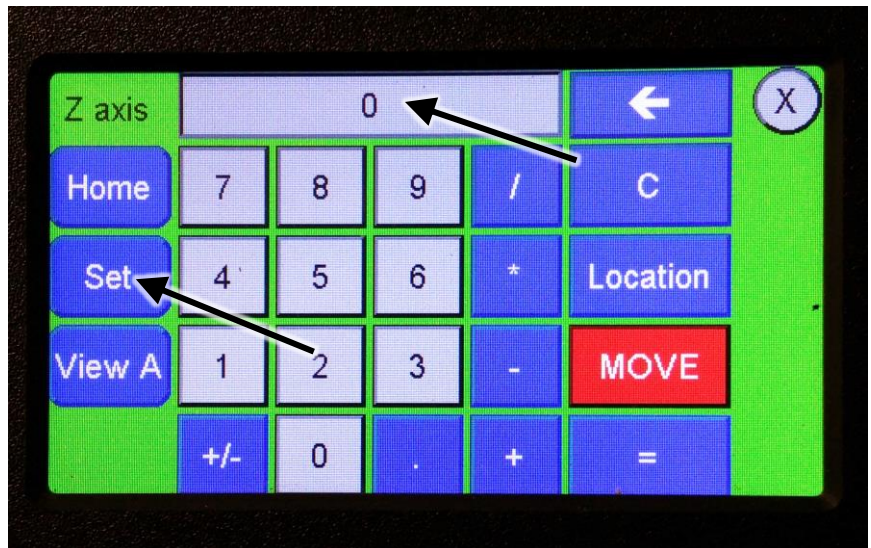

Step 4 – Enter 0 for the value and then press Set.

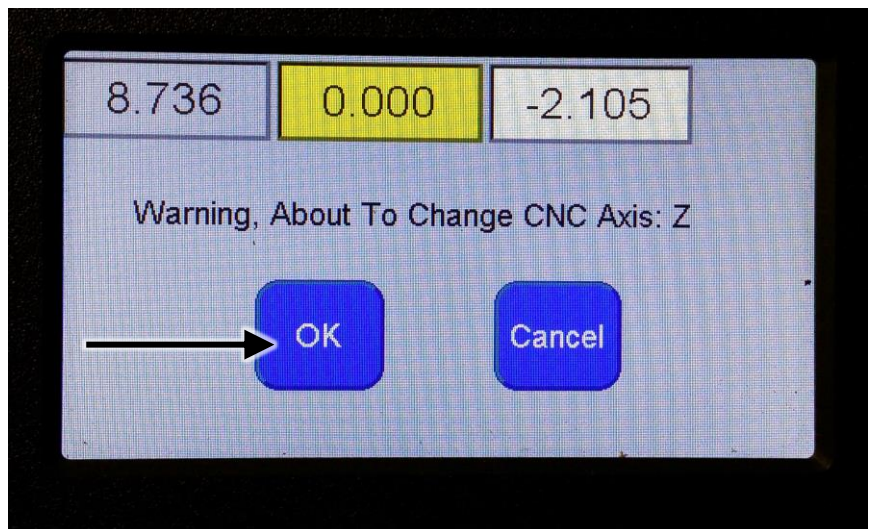

Step 5 – Press OK to accept change.

Step 6 – The Z field will now read Zero

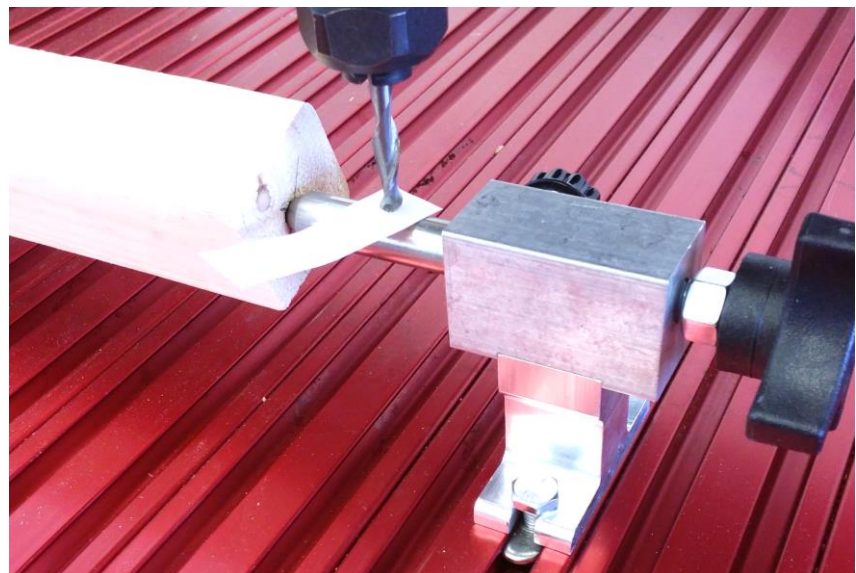
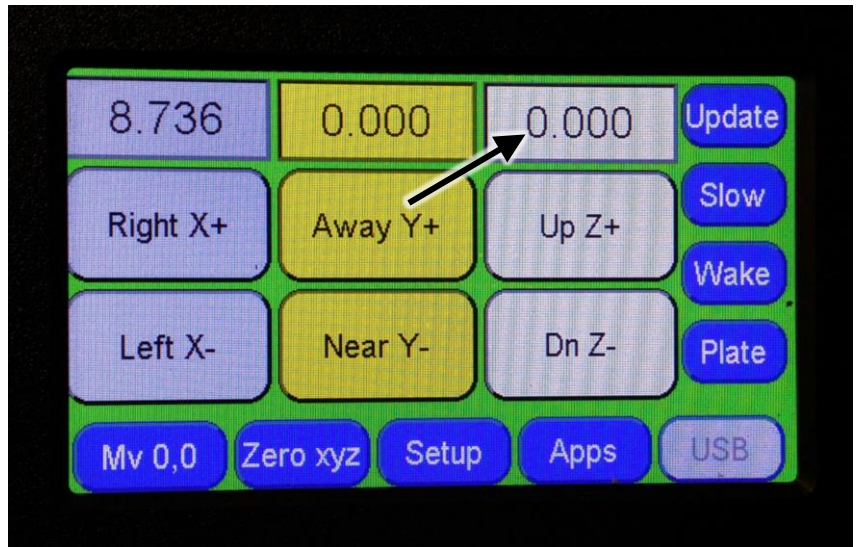

Step 7 – Slowly jog the bit over and down to the top of a piece of paper on the tailstock center

Step 8 – Record the number shown in the Z axis field and write it down " as a **positive** number"

(NOTE: Your number may not exactly match the one shown here.)

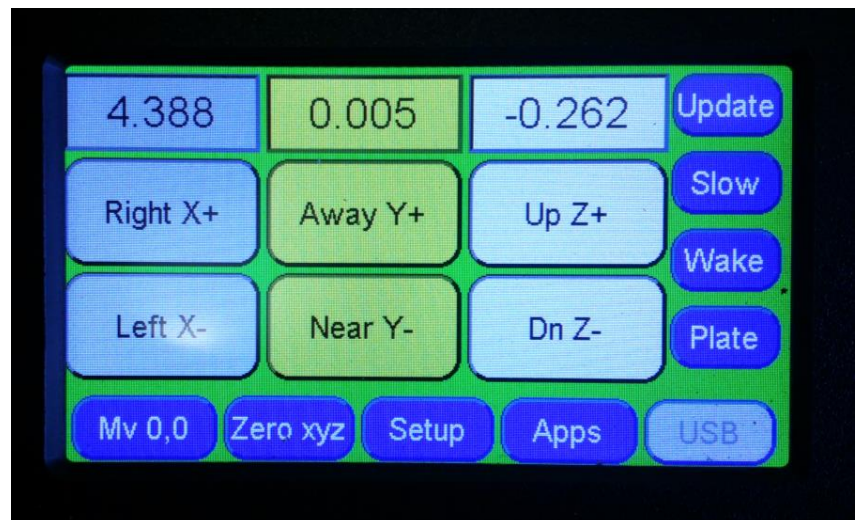

Rotary 4th Axis Workflow Practice Project (Cont.)

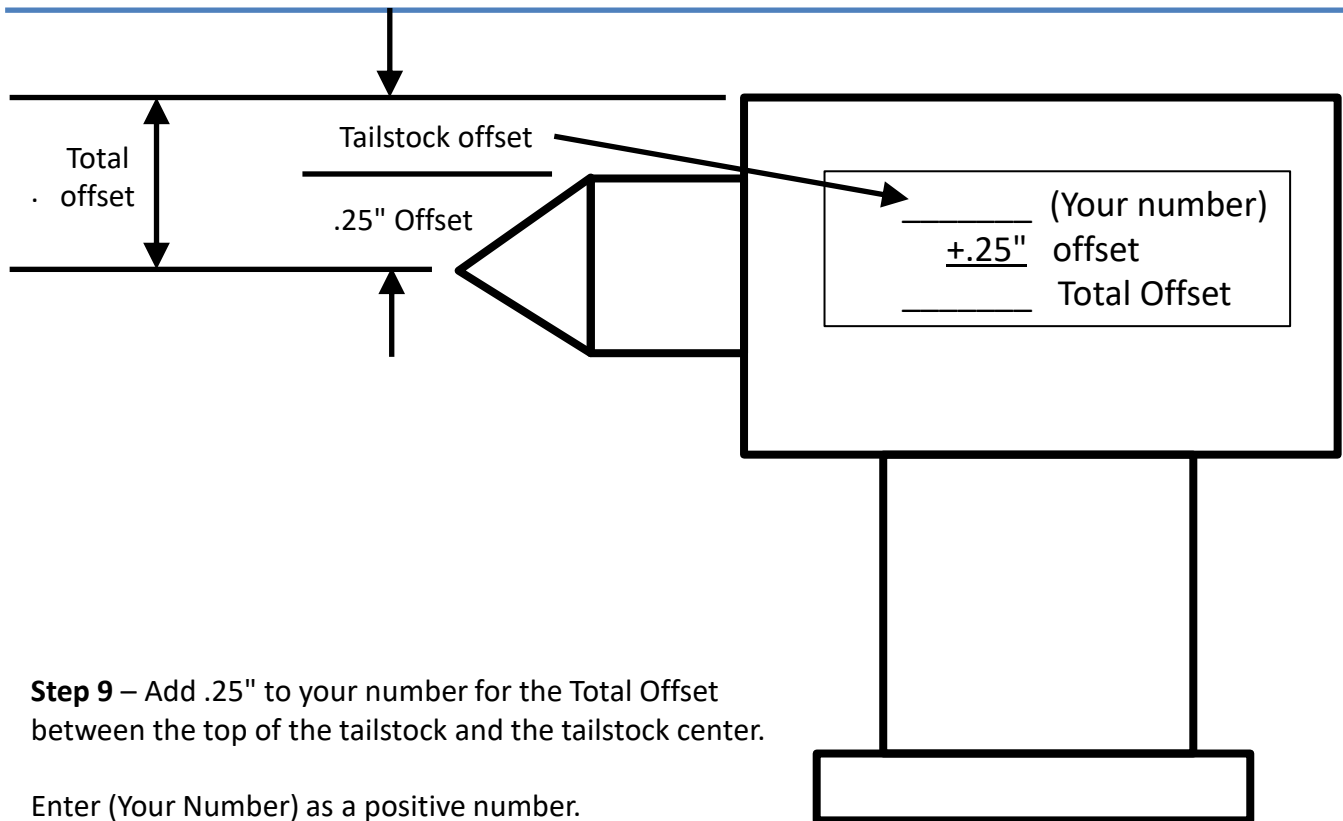

Step 9 – Add .25" to your number for the Total Offset between the top of the tailstock and the tailstock center.

Enter (Your Number) as a positive number.

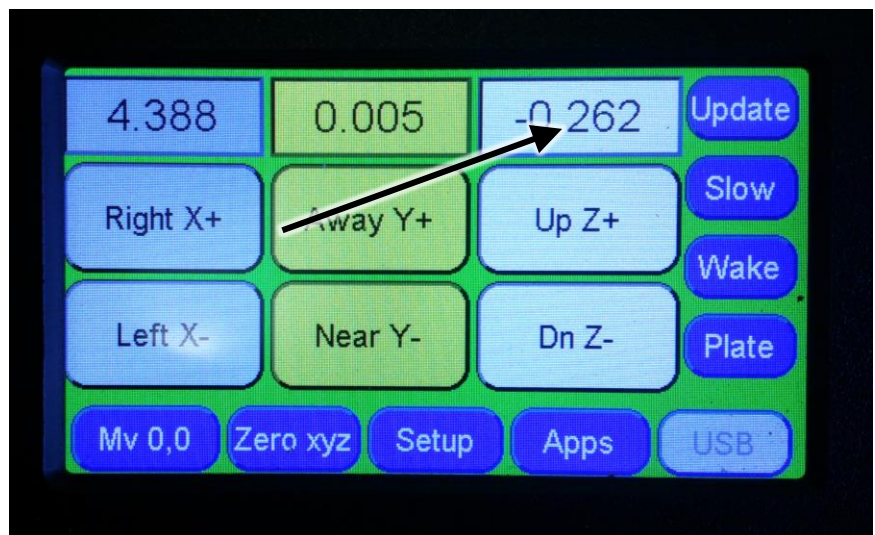

Step 10 – Press on the Z Position field to open the Z keypad.

Step 11 – Press **Home** button. This will raise the the tip of the bit to the current Z, **0** position, and level with the top of the tailstock.

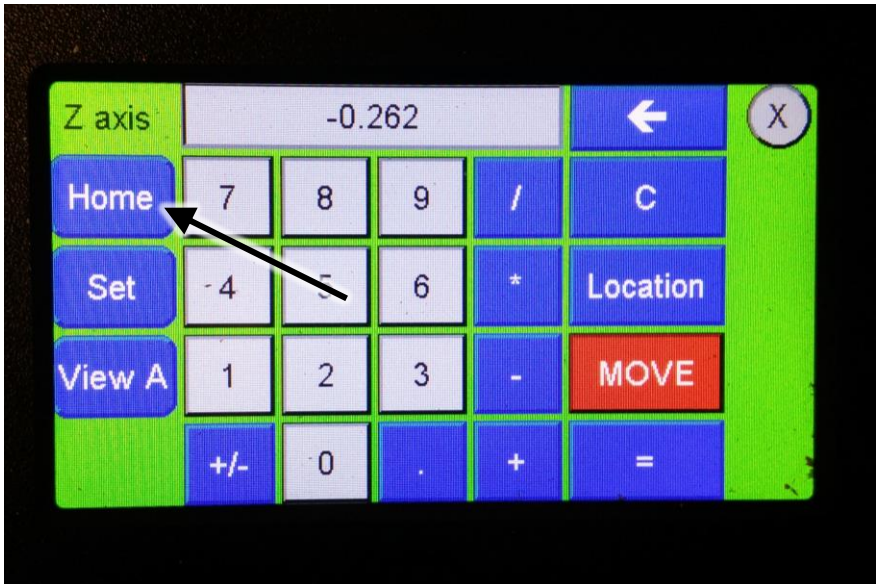

Step 12a – The Z position field should now read 0.000

Step 12b – Press the Z position field to open the Z keypad again.

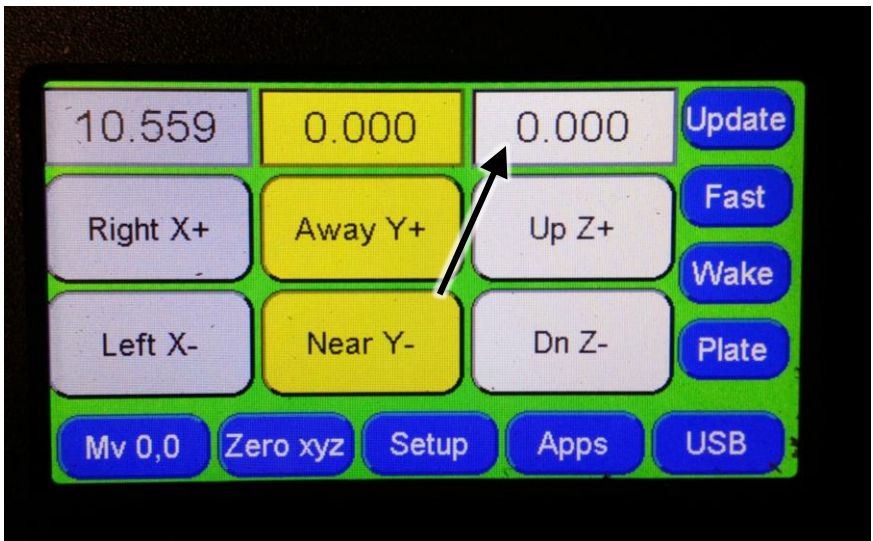

Step 13– Enter the tool Offset you calculated in Step 20 and press **Set**.

(NOTE: Your number may not match the one shown here.)

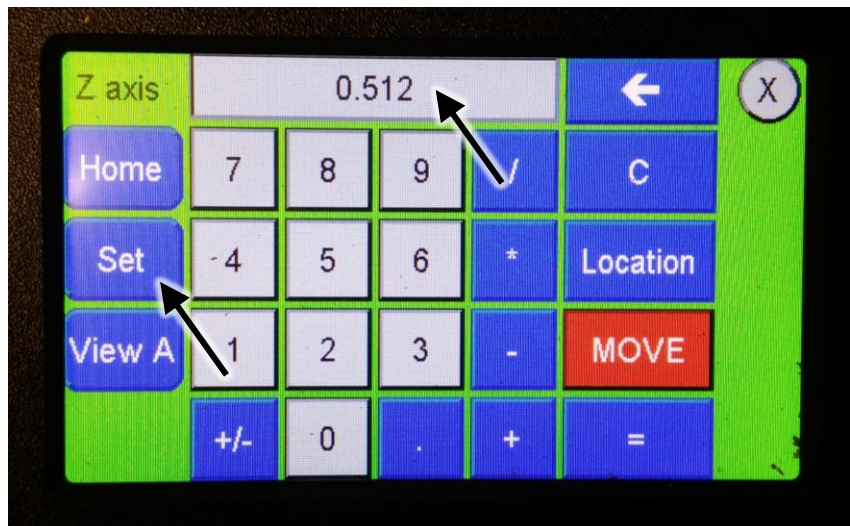

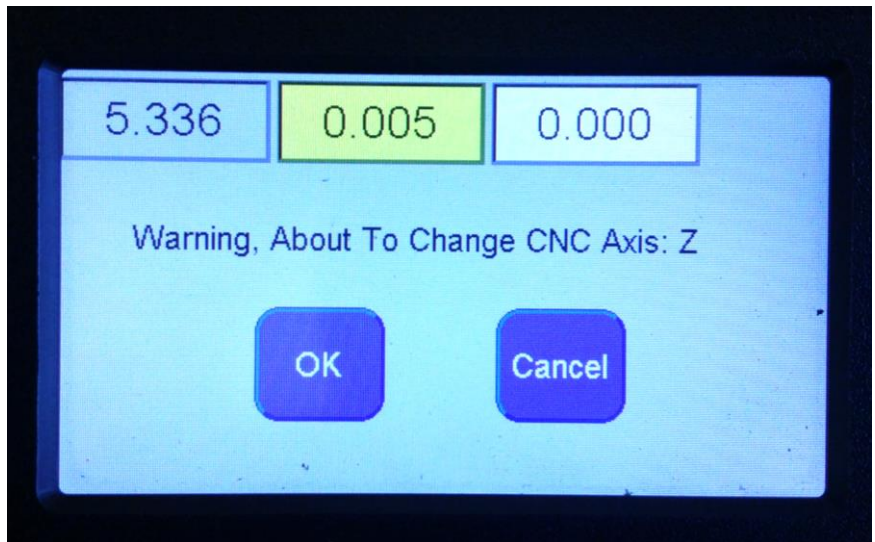

Step 14 – Press OK

Step 15 – The Z is now zeroed to the center of the workpiece. The Z window shows .512 because the tip of the router bit is .512 above the center of the workpiece.

(NOTE: Your number may not match the one shown here.)



Step 16 – The bottom of the router bit should be level with the top of the tailstock.

For easy reference, add a label to the tailstock with the Total Offset amount.

(NOTE: Your number may not match the one shown here.)

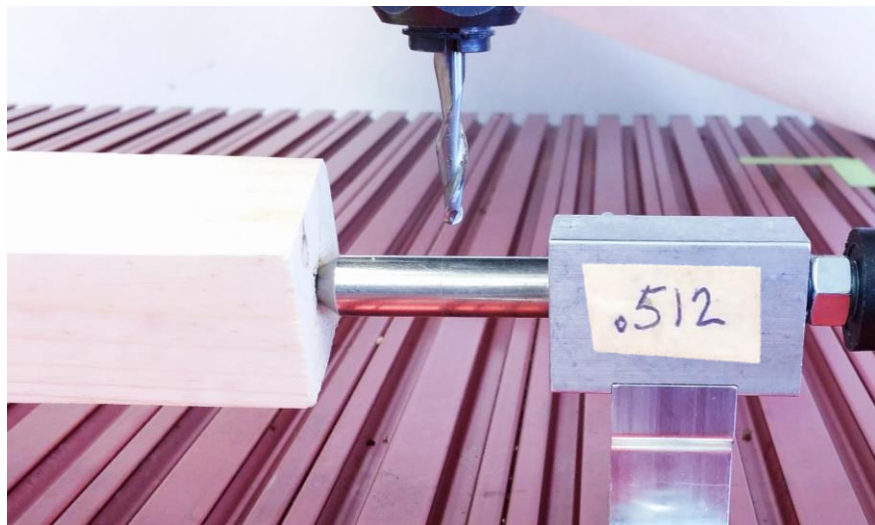

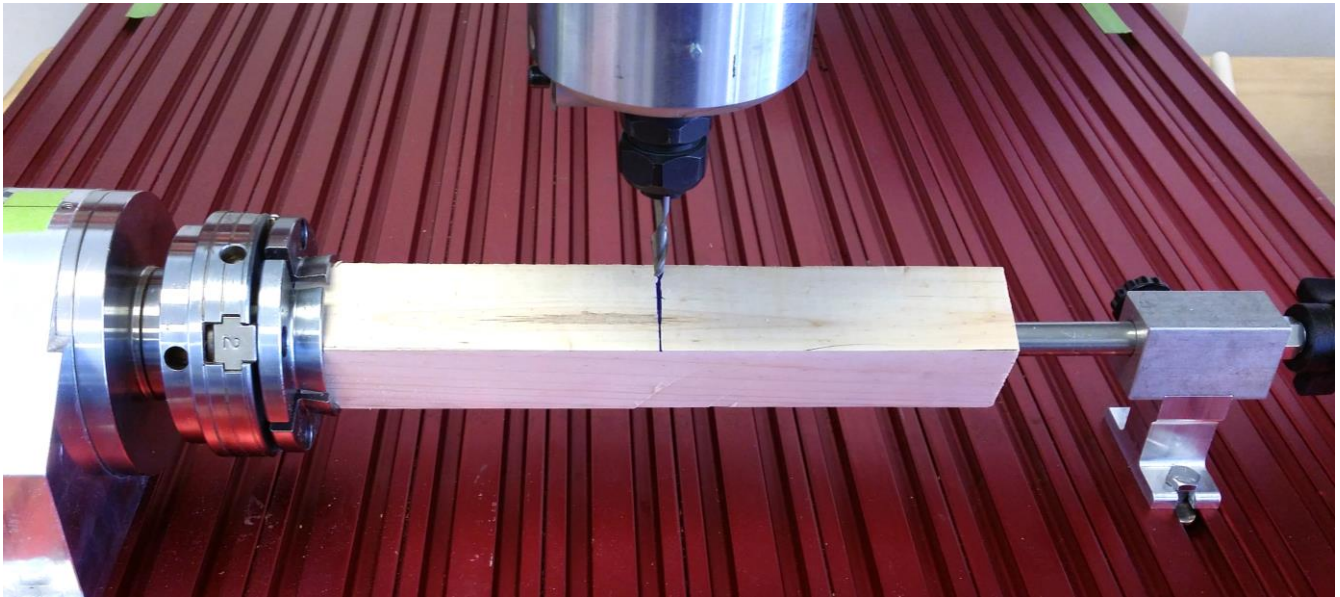

Step 17 – Raise the Z up so it clears the workpiece and jog over to the middle (X center) of the workpiece.

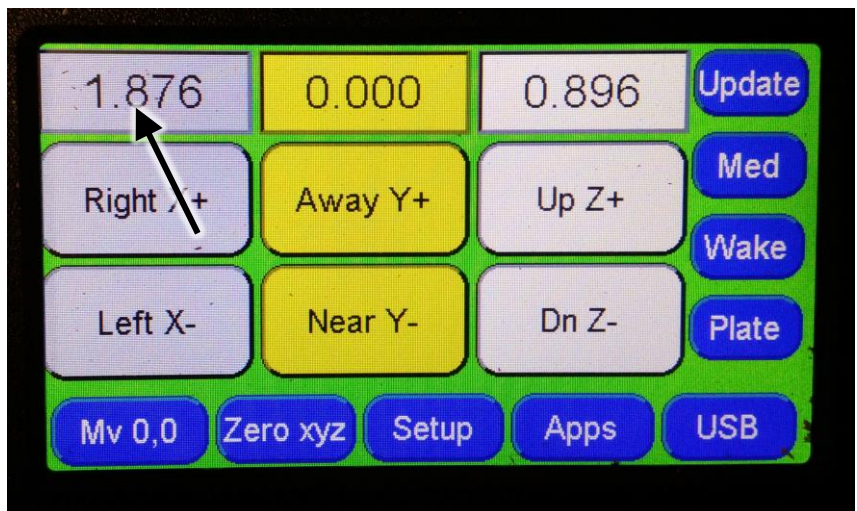

Step 18 – Press the X position field to open the X keypad

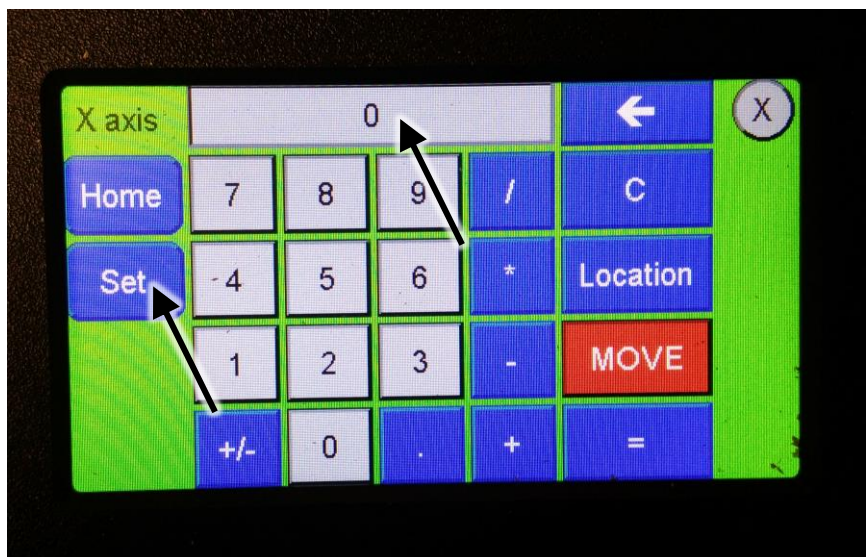

Step 19 – Enter 0, and press Set.

This will zero the X to the left-right center of your workpiece.

Step 20 – The XYZ axes are now all zeroed, but we still need to zero "4th axis", which is called the "A" Axis. To access the A axis press on the Z position field to open the Z keyboard.

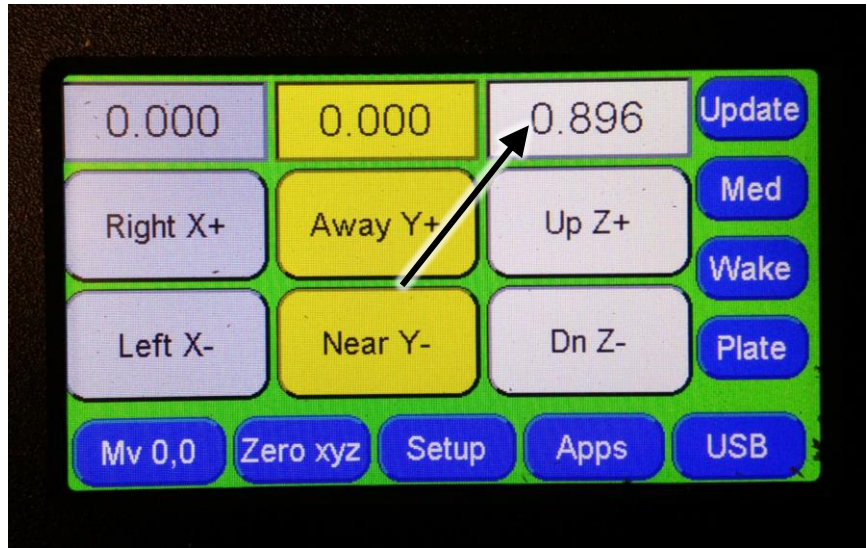

Step 21 – Press **View A**. This will switch the keyboard to the A axis.

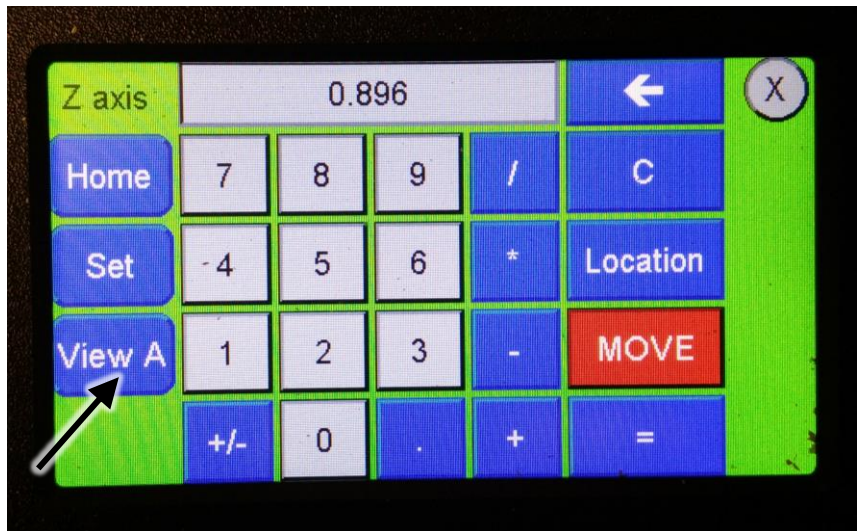

Step 22 – The keypad now provides control of the A axis. Press the X to close this window

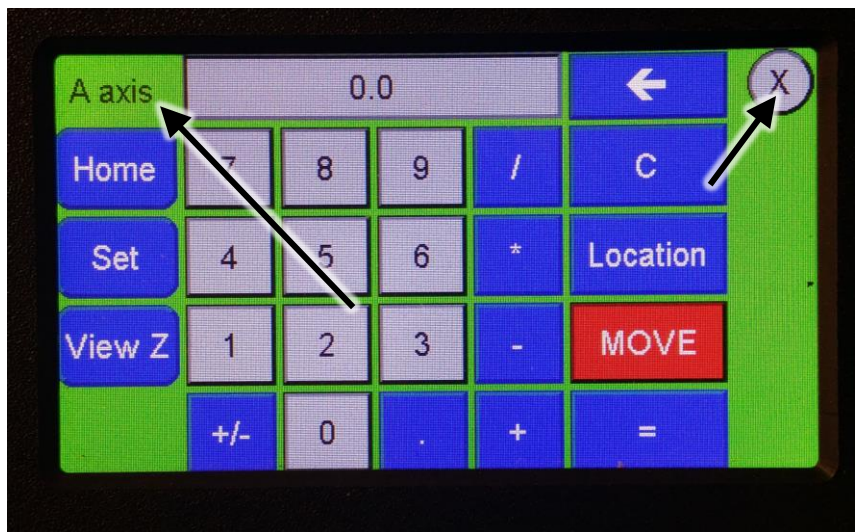

Step 23 – The A Axis controls now appear in the main window. You can switch back and forth whenever you need to make a change to the A or the Z.

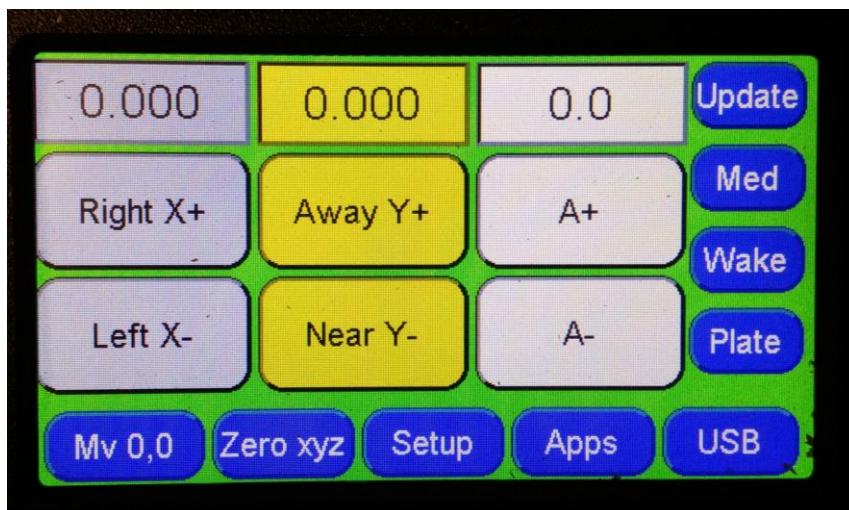

Step 24 – Use the A axis controls on the pendant to rotate the stock so it is square with the table. If you're using round stock, you can skip this step.

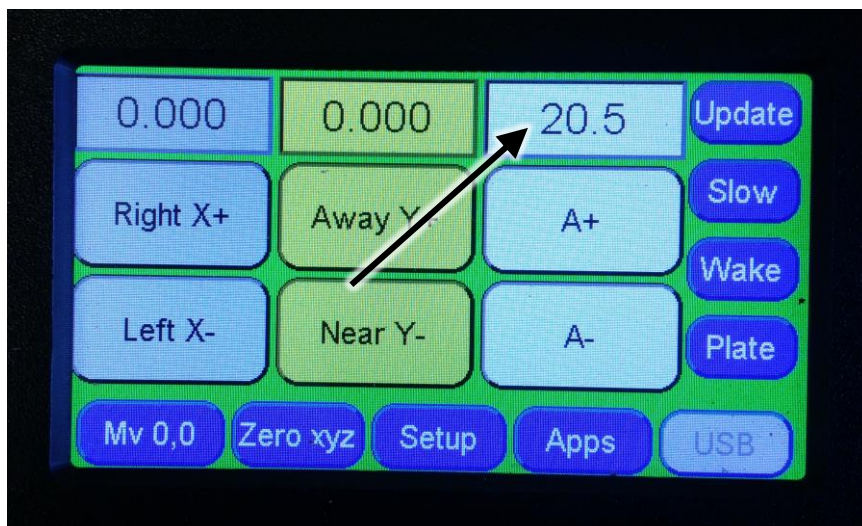

Step 25 – Press on the A position field to open the A keypad

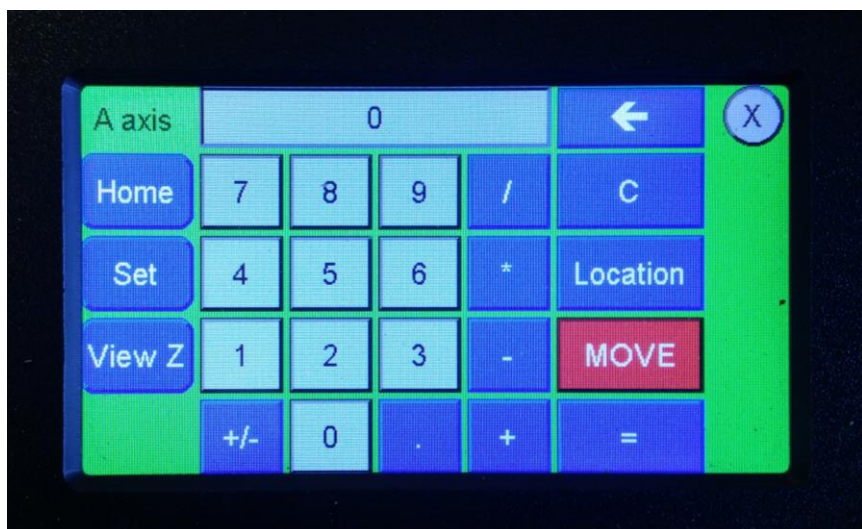

Step 26 – Enter 0 and press the Set button.

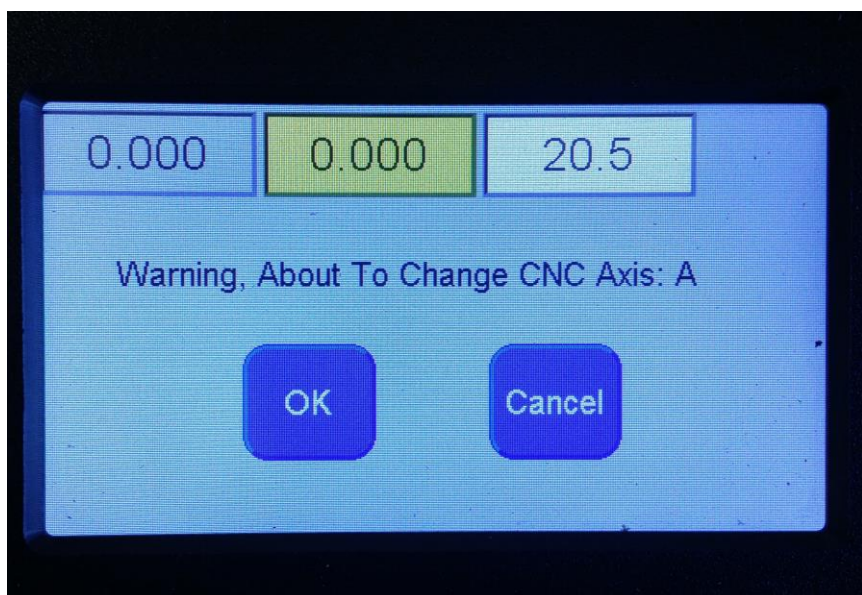

Step 27– Press OK to accept the change.

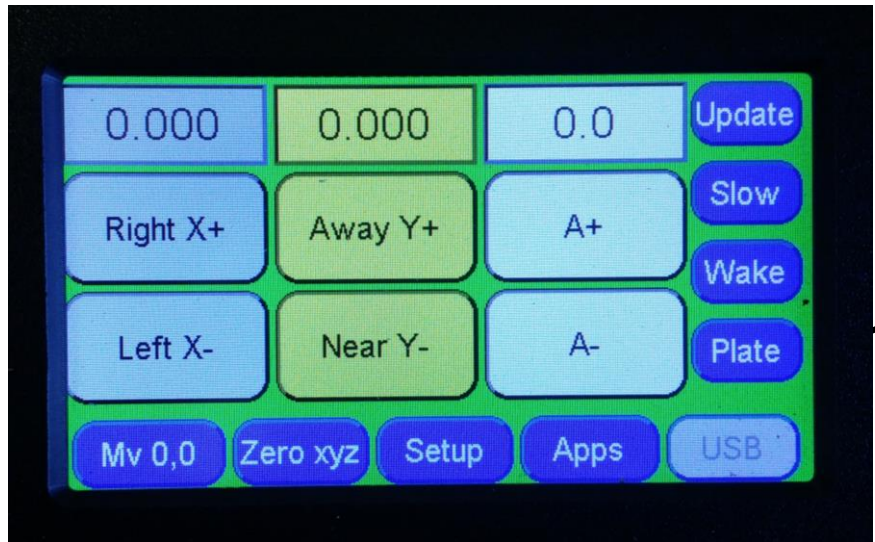

Step 28 – All four axis are now zeroed

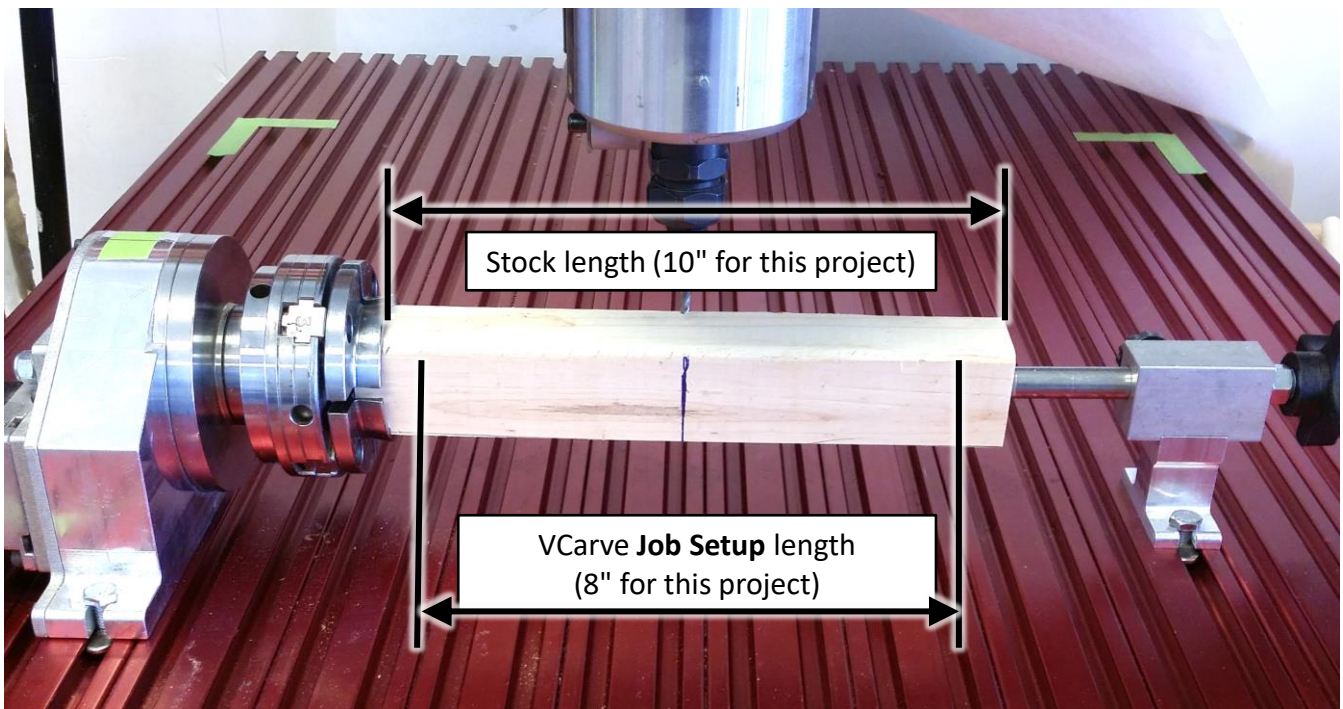

Step 29 – Before you run your file it's **important** to double check your setup. It's especially important to make sure that the axes are zeroed correctly and that your stock is long enough to accommodate the project. A mistake can result in the router bit cutting into the headstock and/or tailstock. Using stock that is longer than your project setup is a good practice and helps avoid bit collisions with the head or tail stocks

Step 30 – Load the toolpath .tap files and start them in the same way you do for your 3-axis projects.

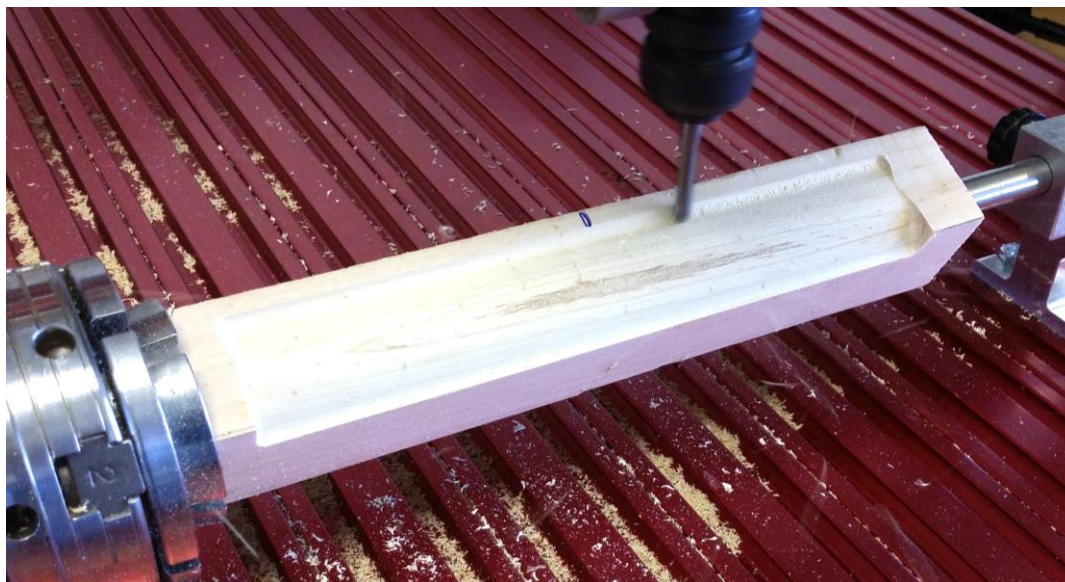

Step 31 – The Rounding toolpath machines the square stock down to a round cylinder. Rounding is accomplished differently in VCarve Desktop from VCarve Pro, but the result is the same.



Step 32 – The surface of the the cylinder can be decorated using a variety of 2D and 3D tools. You can find more information on rotary design and machining at [www. Vectric.com](http://www.Vectric.com)

Rotary 4th axis tools are capable of creating a variety of decorative "in-the-round" projects. For more detailed information on creating advanced rotary projects and other CNC projects visit www.NextWaveCNC.com/cncprojectplans and www.Vectric.com

Maintenance

Before each use

- Check for damaged wires or components. Repair or replace as needed.
- Check for loose or worn parts. Tighten, adjust or replace as needed.

After each use

- Dust, vacuum and wipe as needed to remove chips and dust.

Every 8 hours of use

- Add a few drops of light machine oil to oil hole shown in the pictures below.

As needed

- Jaw Chuck - Use a soft brush to remove dust build-up from parts and lubricate with a light machine oil. Wipe off excess.

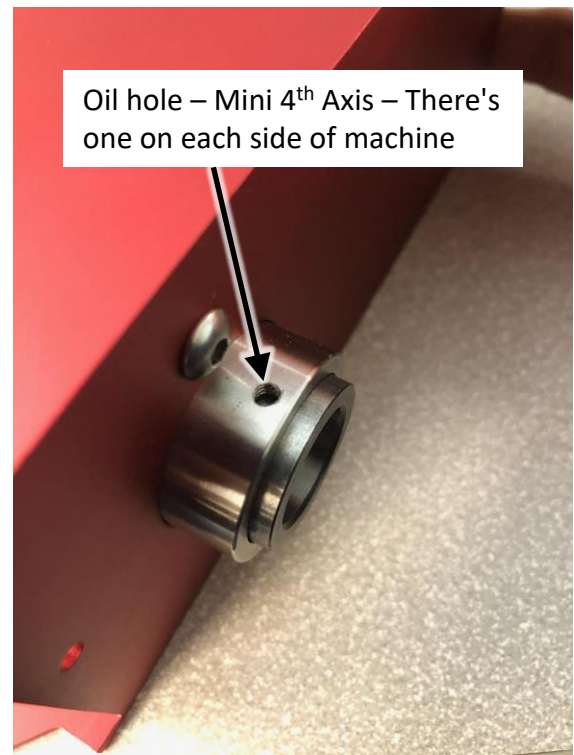

NOTES PAGE



Rotary 4th Axis Owners Manual
May 2020